

Strainers

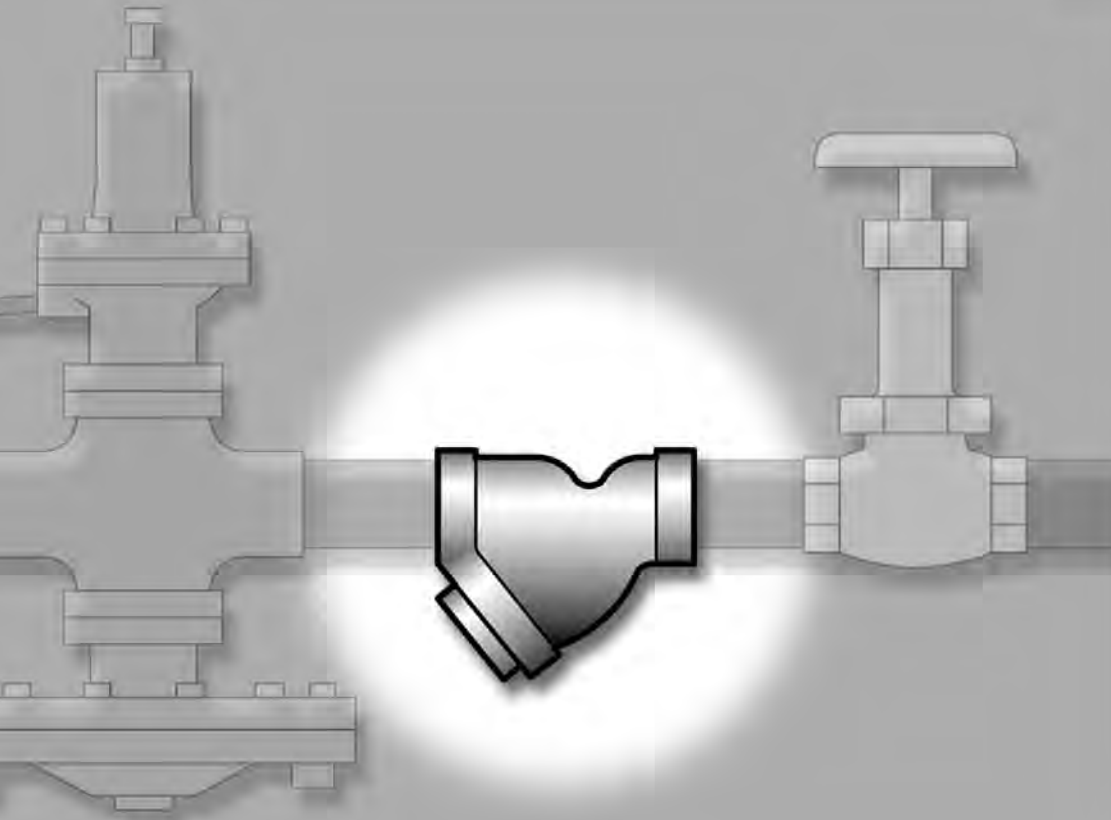

**Armstrong**



# Strainer

### Tight seating

Both ends of the chamber are precisely machined to provide perfectly round and smooth seating surfaces as well as fixed chamber length. The screen seats snugly on the machined surface so no particle larger than the screen opening can escape around the end of the screen.

### Choice of body materials

Cast iron, carbon steel, chrome moly, forged steel, stainless steel, bronze.

### Connection configurations available

Select screwed, socketweld or flanged.

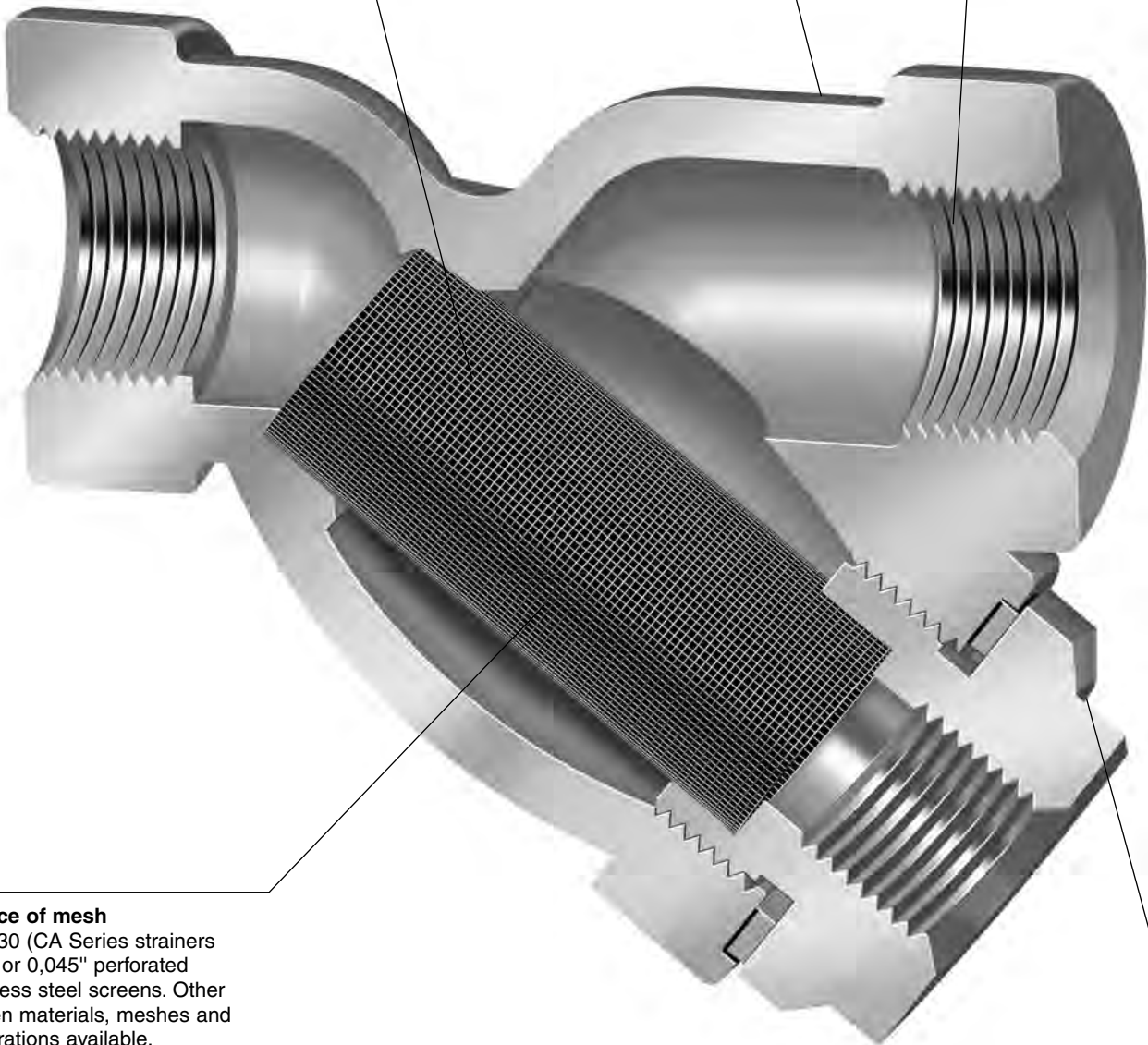

### Choice of mesh

30 x 30 (CA Series strainers only) or 0,045" perforated stainless steel screens. Other screen materials, meshes and perforations available.

### Easy-in, easy-out screwed screen retainers

Straight threads mean less torque is required to obtain a tight seal with proper gasket compression, and less torque is required to remove the retainer. The danger of "freezing in" is considerably less than with hard-to-break tapered pipe threads.

# Armstrong Y-Type Strainers



## Design Advantages

**No-Leak, No-Crush Screen Chambers** are assured by precise machining of both ends of the chamber to provide perfectly round and smooth seating surfaces as well as fixed chamber length. The screen seats snugly on the machined surface so no particle larger than the screen opening can escape around the end of the screen.

**Easy-In, Easy-Out Screwed Screen Retainers** have straight threads. Less torque is required to obtain a tight seal with proper gasket compression. Less torque is required to remove the retainer. The danger of "freezing in" is considerably less than with hard-to-break tapered pipe threads.

**Off-Center Blowdown Connections** for 2 1/2" and 3" size strainers. The off-center drain permits nearly complete removal of liquid and dirt when blowing down the strainer. And less liquid spills when removing the screen retainer.

## How To Order

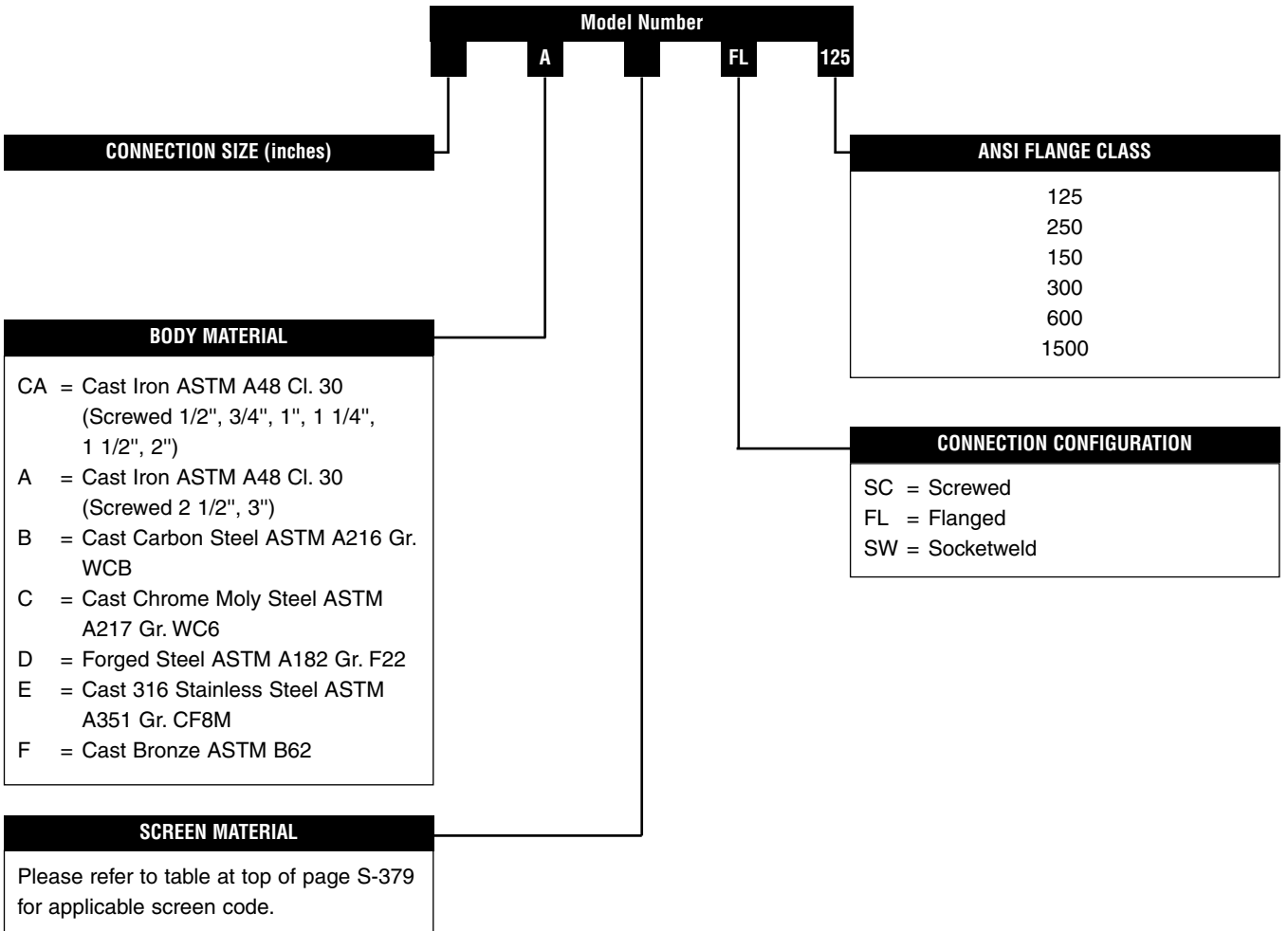

Strainers

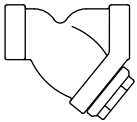
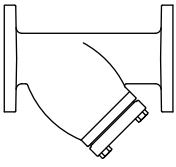
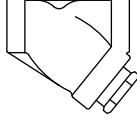
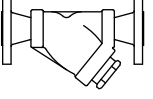
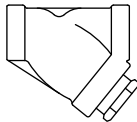
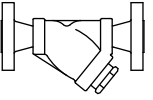
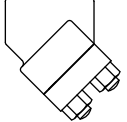
Table S-376-1. Armstrong Strainers										
Illustration	Model	Connection Size	Connection Type	Body Material	Pressure Temperature Ratings		Located on Page			
					Steam Non-shock	Cold Non-shock				
	CA	1/2", 3/4", 1", 1 1/4", 1 1/2", 2"	Screwed	Cast Iron ASTM-A48 Class 30	17 bar @ 208°C	28 bar @ 66°C	S-380			
	A	2 1/2", 3"					S-380			
	A	2"	Class 125 Flanged		Cast Carbon Steel ASTM-A216 Gr. WCB	8,6 bar @ 178°C	12 bar @ 66°C	S-381		
	A	2 1/2" - 10"								
	A	2"	Class 250 Flanged			17 bar @ 208°C	28 bar @ 66°C			
	A	2 1/2" - 8"								
	B	1/2", 3/4", 1"	Screwed & Socketweld 900 lb		Cast Carbon Steel ASTM-A216 Gr. WCB	113 bar @ 321°C	153 bar @ 38°C	S-382		
	B	1 1/4", 1 1/2", 2", 3"	Screwed & Socketweld 600 lb						78 bar @ 294°C	102 bar @ 38°C
	B	1/2", 3/4", 1"	Class 150 Flanged	Cast Carbon Steel ASTM-A216 Gr. WCB		14 bar @ 199°C	20 bar @ 38°C	S-383		
	B	1 1/4", 1 1/2", 2", 3"								
	B	4", 6"								
	B	1/2", 3/4", 1"	Class 300 Flanged			42 bar @ 254°C	51 bar @ 38°C			
	B	1 1/4", 1 1/2", 2", 3"								
	B	4", 6"								
	B	1/2", 3/4", 1"	Class 600 Flanged		78 bar @ 294°C	102 bar @ 38°C				
	B	1 1/4", 1 1/2", 2", 3"								
B	4"									
	C	1/2", 3/4", 1"	Screwed & Socketweld 1 500 lb	Cast Chrome Moly Steel ASTM-A217 Gr. WC6	144 bar @ 339°C	207 bar @ 38°C	S-384			
	C	1 1/4", 1 1/2", 2"						173 bar @ 354°C	248 bar @ 38°C	
	C	1/2", 3/4", 1"	Class 1 500 Flanged		Cast Chrome Moly Steel ASTM-A217 Gr. WC6	144 bar @ 339°C		207 bar @ 38°C		
	C	1 1/4", 1 1/2", 2"							173 bar @ 354°C	248 bar @ 38°C
	D	1/2", 3/4", 1", 1 1/4", 1 1/2", 2"	Socketweld 2 500 lb			Forged Steel ASTM-A182 Gr. F22		172 bar @ 552°C	414 bar @ 38°C	S-385

# Strainers ID Charts

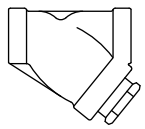
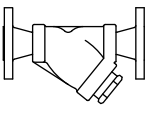
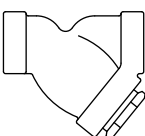

Table S-377-1. Armstrong Strainers							
Illustration	Model	Connection Size	Connection Type	Body Material	Pressure Temperature Ratings		Located on Page
					Steam Non-shock	Cold Non-shock	
	E	1/2", 3/4", 1"	Screwed & Socketweld 1 500 lb	Cast Stainless Steel ASTM-A351 Gr. CF8M	144 bar @ 339°C	207 bar @ 38°C	S-386
	E	1 1/4", 1 1/2", 2", 3"	Screwed & Socketweld 600 lb		64 bar @ 281°C	99 bar @ 38°C	
	E	1/2", 3/4", 1"	Class 150 Flanged	Cast Stainless Steel ASTM-A351 Gr. CF8M	14 bar @ 197°C	19 bar @ 38°C	S-387
	E	1 1/2", 2", 3"					
	E	4", 6"					
	E	1/2", 3/4", 1"	Class 300 Flanged		34 bar @ 242°C	50 bar @ 38°C	
	E	1 1/2", 2", 3"					
	E	4", 6"					
	E	1/2", 3/4", 1"	Class 600 Flanged		64 bar @ 282°C	99 bar @ 38°C	
	E	1 1/2", 2", 3"					
E	4"						
	F	1/2", 3/4", 1", 1 1/4"	Screwed 300 lb	Cast Bronze ASTM-B62	21 bar @ 217°C	34 bar @ 66°C	S-388
	F	1 1/2", 2"					

All models comply with the Pressure Equipment Directive PED 97/23/EC. For details, see specific product page or Armstrong PED Certificate.

Strainers



# Screen Data



Screen Specification	Particle Retention mm	Back-Up Screen Required	Materials				
			304 SS	Monel	Brass	316 SS	
Perforated	1/64"	0,4064	3" – 10"	Code 10	Code 18	–	–
	1/32"	0,7874	None	Code 11	Code 19	–	Code 31
	0,045 (3/64")	1,1430	None	Code 1	Code 3	Code 4	Code 7
	1/16"	1,5748	None	Code 12	–	–	Code 32
	1/8"	3,1750	None	Code 8	Code 21	Code 28	Code 33
	3/16"	4,7752	None	Code 13	Code 22	–	Code 34
Mesh	1/4"	6,3500	None	Code 14	Code 23	–	Code 35
	20 x 20	0,8636	6" – 10"*	Code 15	Code 5**	–	–
	24 x 110	0,1422	5" – 10"	–	Code 24	–	Code 2
	30 x 30	0,5080	None	Code 41 (1)	–	–	–
	40 x 40	0,3810	1 1/2" – 10"	Code 16	Code 6	–	Code 37
	100 x 100	0,1397	All sizes	Code 9	Code 25	–	Code 38
	150 x 150	0,1041	All sizes	Code 40	–	–	–
200 x 200	0,0737	All sizes	Code 17	–	–	Code 39	

\* Except 6" – 125 lb cast iron

\*\* On Code 5 – 2 1/2" thru 10" require back-up screen

Shade indicates only available screen choices for CA Series Strainers.

(1) 30 x 30 mesh screen only available for CA Series Strainers.

Strainer Size	Total Screen Area, cm <sup>2</sup>	Inside Area of Pipe, cm <sup>2</sup>	Ratio – Perforated Screens							Ratio – Wire Mesh Screens					
			1/64"	1/32"	0,045"	1/16"	1/8"	3/16"	1/4"	24 x 110	20 x 20	30 x 30	40 x 40	100 x 100	200 x 200
1/2"	46,45	1,94	5,2	5,0	6,4 (5)	5,2	6,9 (5,4)	8,8	10,0	4,8 (3,8)	6,6	7,2	5,2 (4,1)	2,2 (1,8)	2,5
3/4"	46,45	3,42	4,0	3,9	5,0	4,0	5,4	6,9	7,8	3,8	5,3	7,2	4,1	1,8	2,0
1"	70,97	5,55	3,8	3,7	4,7	3,8	5,1	6,5	7,4	3,7	5,2	11,0	4,0	1,7	1,9
1 1/4"	102,6	9,61	3,2	3,0	3,9	3,2	4,2	5,4	6,1	3,2	4,4	–	3,4	1,5	1,6
1 1/2"	152,3	13,10	3,4	3,3	4,3	3,4	4,6	5,9	6,7	3,5	4,8	23,6	2,8	1,6	1,8
2"	221,9	21,61	3,0	2,9	3,8	3,0	4,1	5,2	5,9	3,2	4,4	34,4	2,6	1,5	1,6
2 1/2"	351,0	30,84	3,4	3,3	4,2	3,4	4,5	5,8	6,6	3,3	3,5 †	–	2,7	1,7	1,9
3" 125#	477,4	47,68	1,7	2,9	3,7	3,0	4,0	5,1	5,8	2,9	3,1 †	–	2,3	1,5	1,7
3" 250#	561,3	47,68	2,0	3,4	4,3	3,5	4,7	6,0	6,8	3,5	3,8 †	–	2,8	1,8	2,0
4" 125#	793,5	81,94	1,7	2,8	3,5	2,9	3,8	4,9	5,6	2,8	3,0 †	–	2,3	1,5	1,6
4" 250#	935,5	81,94	2,0	3,3	4,2	3,4	4,5	5,8	6,6	3,4	3,7 †	–	2,1	1,8	2,0
6" 125#	1754	186,5	1,6	2,7	3,4	2,8	3,1	4,8	5,4	1,6	3,0	–	1,8	1,5	1,6
6" 250#	2045	186,5	1,9	3,1	4,0	3,2	4,3	5,5	6,3	1,9	2,7	–	2,1	1,7	1,9
8" 125#	2994	322,6	1,6	2,6	3,4	2,7	3,7	4,7	5,3	1,6	2,3	–	1,8	1,5	1,7
8" 250#	3548	322,6	1,9	3,1	4,0	3,3	4,4	5,6	6,3	2,0	2,8	–	2,1	1,8	2,0
10" 125#	4729	508,4	1,6	2,7	3,4	2,7	3,7	4,7	5,4	1,7	2,3	–	1,8	1,5	1,7
<b>Percentage Open Area</b>			30%*	29%	37%	30%	40%	51%	58%	33%*	46%*	37%	36%*	–	–

**Notes:** Cast steel, stainless steel and bronze strainers have the same ratios as 250 lb cast iron. This table does not apply to the Forged Steel F22 Strainers on page S-385.

Numbers in parentheses apply to CA cast iron series only.

\* For unbacked screens.

† Back-up required, Monel only.

Shade indicates that back-up screens are required.

Strainers



# Cast Iron 250 lb Screwed 1/2" - 3"

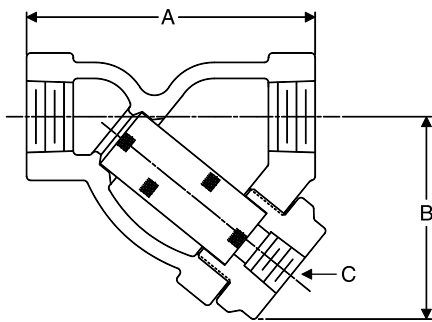

CA1SC/CA41SC 1/2", 3/4", 1", 1 1/2", 2"

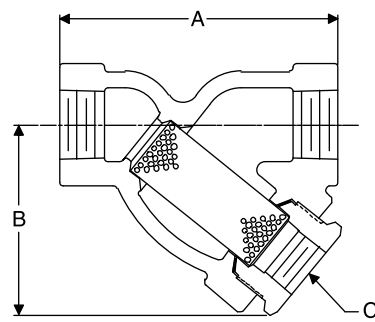

CA1SC/CA41SC 1 1/4"

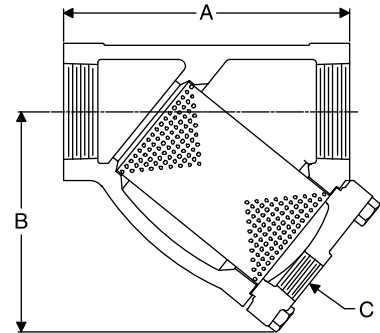

A1SC 2 1/2", 3"

### Pressure/Temperature Rating

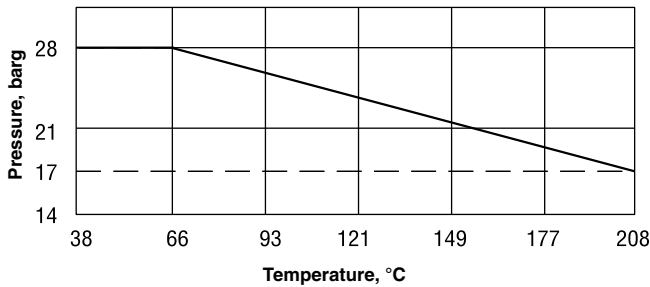

Table S-380-1. Materials: 250 lb Screwed 1/2" - 3"

Connection Size in	Body	Standard Screen	Screen Retainer	Gasket	Bolting
1/2", 3/4"	ASTM A48 Class 30 Cast Iron	30x30 SS Mesh or 304 SS 0,045" perforated †	ASTM A48 Class 30 Cast Iron	Spiral wound	N/A
1", 1 1/2", 2"				Soft Steel	
1 1/4"				Non-asbestos	
2 1/2", 3"					

† Note: Other screen materials available. See page S-379.

Table S-380-2. Physical Data: 250 lb Screwed 1/2" - 3"

Connection Size in	Ordering Code, Standard Screen	Weight kg	Dimensions			Maximum Pressure		Screen Retainer Type	Connections
			A mm	B mm	C in	Saturated Steam bar	66°C non-shock bar		
1/2"	CA1SC CA41SC	1,4	108	76	3/8"	17	28	Threaded	ANSI B1.20.1 Screwed
3/4"		2,0	127	95	1/2"				
1"		3,0	140	98					
1 1/4"		4,5	160	113					
1 1/2"		6,8	191	138					
2"	A1SC	11,0	216	164	3/4"			Bolted	
2 1/2"		21,0	267	203	1 1/4"				
3"									

All sizes comply with the article 3.3 of the PED (97/23/EC).

All dimensions and weights are approximate. Use certified print for exact dimensions. Design and materials are subject to change without notice.



# Cast Iron Class 125 Flanged 2" - 10" and Class 250 Flanged 2" - 8"

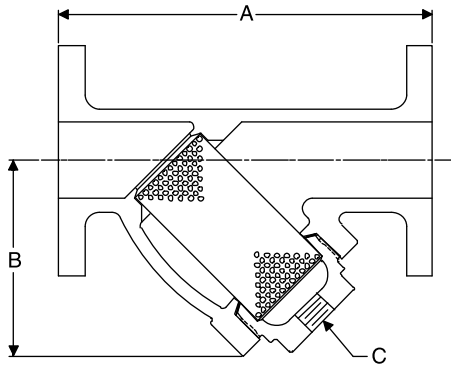

2" Class 125 or 250 Flanged

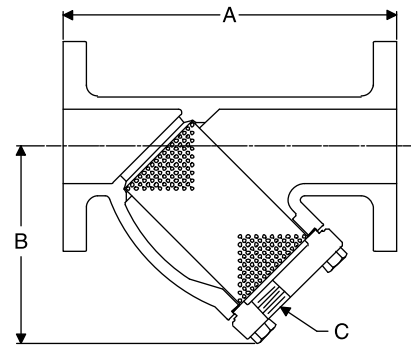

2 1/2" - 10" Class 125 Flanged, 2 1/2" - 8" Class 250 Flanged



Connection Size in	Body	Screen Retainer	Gasket	Bolting	Standard screen
2"	ASTM A48 Class 30 Cast Iron		Soft Steel	N/A	304 SS 0,045" perforated †
2 1/2", 3", 4", 6", 8"				Cap Screws ASTM A193	304 SS 1/8" perforated †
10" Class 125 Only			Non-asbestos		

† Note: Other screen materials available. See page S-379.

Connection Size in	Ordering Code, Standard Screen	Weight kg	Dimensions			Maximum Pressure		Screen Retainer Type	Connection
			A mm	B mm	C in	Saturated Steam bar	66°C non-shock bar		
2"	A1FL 125	10	248	130	1/2"	8,6	12	Threaded	Class 125 ANSI B16.1 Flat Faced
2 1/2"		16	281	164	3/4"				
3"		22	311	184	1 1/4"			Bolted	
4"		38	378	241	1 1/4"				
6"	A1FL 125	85	519	353	1 1/2"	8,6	12	Bolted	
8"		145	603	451	2"				
10"	A8FL 125	257	746	546	2"				
2"	A1FL 250	11	260	130	1/2"	17	28	Threaded	
2 1/2"		19	297	164	3/4"				
3"		32	359	216	1 1/4"			Bolted	
4"		57	435	273	1 1/4"				
6"		133	597	400	1 1/2"				
8"		230	699	514	2"				

Shade indicates products that are CE Marked according to the PED (97/23/EC). All the other sizes comply with the Article 3.3 of the same directive.

All dimensions and weights are approximate. Use certified print for exact dimensions. Design and materials are subject to change without notice.



# Cast Carbon Steel (WCB) 600 lb and 900 lb Screwed or Socketweld 1/2" - 3"

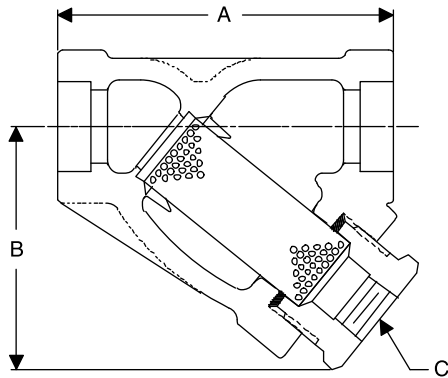

900 lb – B1SC/B1SW 1/2", 3/4", 1"

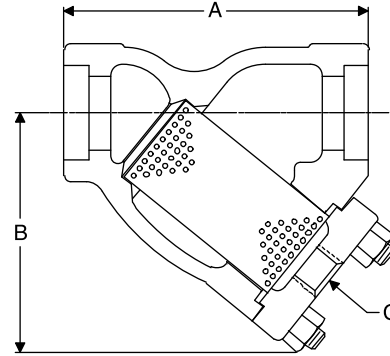

600 lb – B1SC/B1SW 1 1/4", 1 1/2", 2", 3"

### Pressure/Temperature Rating

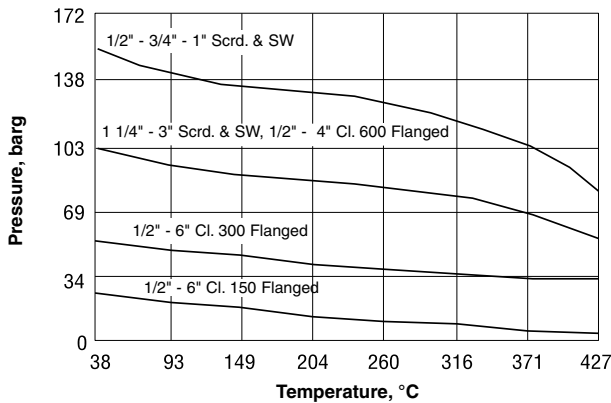

Strainers

**Table S-382-1. Materials: 600 lb and 900 lb Screwed or Socketweld 1/2" - 3"**

Connection Size in	Body	Screen Retainer	Gasket	Bolting	Standard Screen
1/2", 3/4"	ASTM A216 Gr. WCB	ASTM A108 Gr. 1045	Soft Steel	N/A	304 SS 0.045" Perforated +
1"		ASTM A108 Gr. 1040			
1 1/4", 1 1/2", 2"		ASTM A216 Gr. WCB	304 SS Spiral Wound Non-asbestos	Studs ASTM A193 Gr. B7 Nuts ASTM A194 Gr. 2H	
3"			Non-asbestos	Cap screws ASTM A193 Gr. B7	

† Note: Other screen materials available. See page S-379.

**Table S-382-2. Physical Data: 600 lb and 900 lb Screwed or Socketweld 1/2" - 3"**

Connection Size in	Ordering Code Standard Screen		Weight kg	Dimensions			Maximum Pressure		Screen Retainer Type	Connections
	Screwed	SW		A	B	C	Saturated Steam bar	38°C non-shock bar		
1/2"	B1SC	B1SW	1,0	95	68	3/8"	113	153	Threaded	ANSI B1.20.1 Screwed
3/4"			1,6	106	75	1/2"				
1"			2,7	127	89					
1 1/4"	B1SC	B1SW	4,0	140	106	1/2"	78	102	Bolted	ANSI B16.11 Socketweld
1 1/2"			5,0	160	122					
2"			9,0	197	143					
3"			21,0	289	208					

Shade indicates products that are CE Marked according to the PED (97/23/EC). All the other sizes comply with the Article 3.3 of the same directive.

**All dimensions and weights are approximate. Use certified print for exact dimensions. Design and materials are subject to change without notice.**

# Cast Carbon Steel (WCB)

Class 150, 300 Flanged 1/2" - 6" and Class 600 Flanged 1/2" - 4"

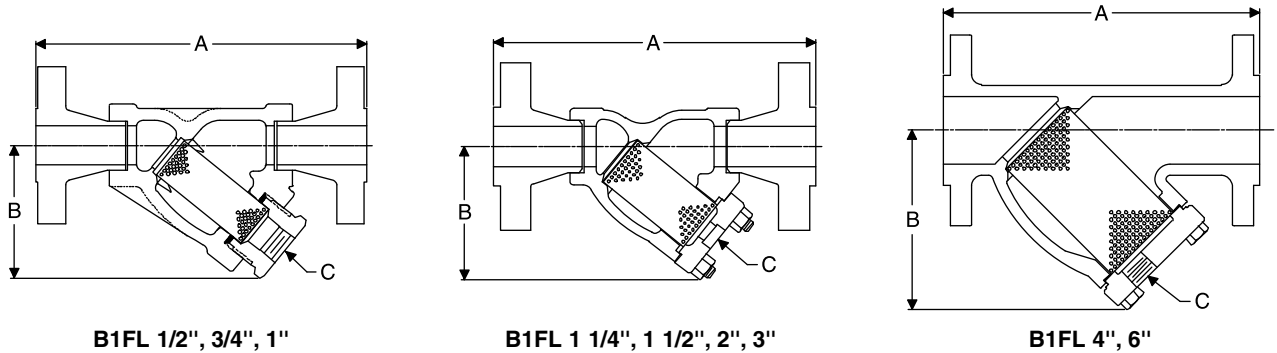

**Table S-383-1. Materials: Class 150, 300 Flanged 1/2" - 6" and Class 600 Flanged 1/2" - 4"**

Connection Size in	Body	Screen Retainer	Gasket	Bolting	Standard screen
1/2", 3/4"	ASTM A216 Gr. WCB	ASTM A108 Gr. 1045	Soft Steel	N/A	304 SS 0,045" Perforated †
1"		ASTM A216 Gr. WCB	304 SS Spiral wound Non-asbestos	Studs ASTM A193 Gr. B7 Nuts ASTM A194 Gr. 2H	
1 1/4", 1 1/2", 2"			Non-asbestos	Cap Screws ASTM A193 Gr. B7	
3", 4", 6"					

† Note: Other screen materials available. See page S-379.

**Table S-383-2. Physical Data: Class 150, 300 Flanged 1/2" - 6" and Class 600 Flanged 1/2" - 4"**

Connection Size in	Ordering Code, Standard Screen	Weight kg	Dimensions			Maximum Pressure		Screen Retainer Type	Flanges	
			A mm	B mm	C in	Saturated Steam bar	38°C non-shock bar			
1/2"	B1FL 150	2,3	175	68	3/8"	14	20	Threaded	Class 150 ANSI B16.5 1/16" RF	
3/4"		4,5	187	75	1/2"					
1"		4,8	216	89						
1 1/4"		7,0	229	106						
1 1/2"		9,0	260	122						
2"		13,0	292	143	1 1/4"					
3"	37,0	397	208							
4"	51,0	422	273							
6"	125,0	575	287	1 1/2"	14	20	Bolted			
1/2"	B1FL 300	3,0	184	68	3/8"	42	51	Threaded	Class 300 ANSI B16.5 1/16" RF	
3/4"		5,0	197	75	1/2"					
1"		6,0	226	89						
1 1/4"		8,0	244	106						
1 1/2"	B1FL 300	12,0	273	122	1/2"	42	51	Bolted		
2"		15,0	308	143						
3"		42,0	416	208	1 1/4"					
4"		59,0	438	273						
6"		137,0	597	387						
1/2"	B1FL 600	5,0	195	68	3/8"	78	102	Threaded	Class 600 ANSI B16.5 1/4" RF	
3/4"		5,4	210	75	1/2"					
1"		6,0	238	89						
1 1/4"	B1FL 600	8,5	260	106	1/2"	78	102	Bolted		
1 1/2"		13,0	287	122						
2"		16,0	324	143						
3"		43,0	435	208						1 1/4"
4"		69,0	464	273						

Note: For pressure/temperature ratings, see page S-382.

Shade indicates products that are CE Marked according to the PED (97/23/EC). All the other sizes comply with the Article 3.3 of the same directive.

All dimensions and weights are approximate. Use certified print for exact dimensions. Design and materials are subject to change without notice.



# Cast Chrome Moly Steel (WC6) 1 500 lb Screwed, Socketweld and Cl. 1 500 Flanged 1/2" - 2"

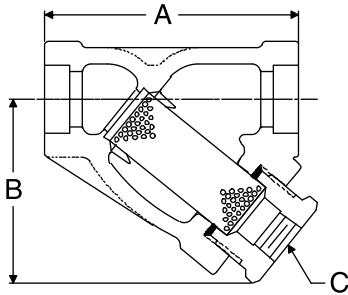

C1SC/C1SW 1/2", 3/4", 1"

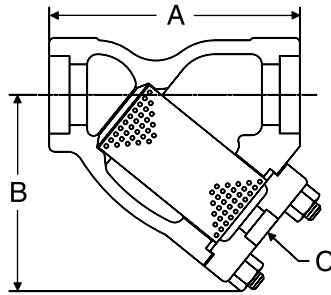

C1SC/C1SW 1 1/4", 1 1/2", 2"

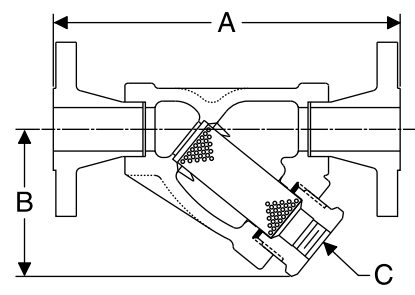

C1FL 1/2", 3/4", 1"

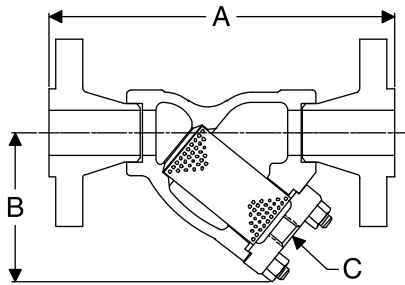

C1FL 1 1/4", 1 1/2", 2"

### Pressure/Temperature Rating

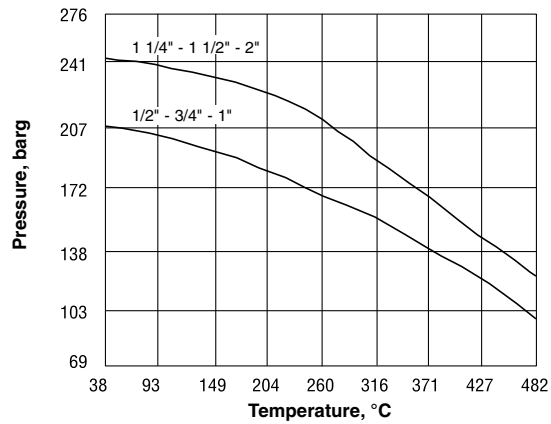

Table S-384-1. Materials: 1 500 lb Screwed, Socketweld and Class 1 500 Flanged 1/2" - 2"

Connection Size in	Body	Screen Retainer	Gasket	Bolting	Standard Screen
1/2", 3/4", 1"	ASTM A217 Gr. WC6	ASTM A276	Soft Steel	N/A	304 SS 0,045" perforated †
1 1/4", 1 1/2", 2"		ASTM A217 Gr. WC6	316L SS Spiral Wound Non-asbestos	Studs ASTM A193 Gr. B16 Nuts ASTM A194 Gr. 2H	

† Note: Other screen materials available. See page S-379.

Table S-384-2. Physical Data: 1 500 lb Screwed, Socketweld and Class 1 500 Flanged 1/2" - 2"

Connection Size in	Ordering Code Standard Screen		Weight kg	Dimensions			Maximum Pressure		Screen Retainer Type	Connections
	Screwed	SW		A mm	B mm	C in	Saturated Steam bar	38°C non-shock bar		
1/2"	C1SC	C1SW	1,1	95	68	3/8"	144	207	Threaded	ANSI B1.20.1 Screwed
3/4"	C1SC	C1SW	1,6	106	75	1/2"				
1"	C1SC	C1SW	2,5	127	89	1/2"				
1 1/4"	C1SC	C1SW*	8,0	171	152	3/4"	173	248	Bolted	ANSI B16.11 Socketweld
1 1/2"	C1SC	C1SW*	8,0	171	152	3/4"				
2"	C1SC	C1SW*	11,0	210	189	1"				
1/2"	C1FL 1500		5,0	210	68	3/8"	144	207	Threaded	Class 1500 ANSI B16.5 1/4" RF
3/4"	C1FL 1500		7,0	238	75	1/2"				
1"	C1FL 1500		10,0	260	89	1/2"				
1 1/4"	C1FL 1500*		17,0	308	152	3/4"	173	248	Bolted	
1 1/2"	C1FL 1500*		20,0	327	152	3/4"				
2"	C1FL 1500*		35,0	397	189	1"				

\* Socketweld Blowdown Connections.

Shade indicates products that are CE Marked according to the PED (97/23/EC). All the other sizes comply with the Article 3.3 of the same directive.

All dimensions and weights are approximate. Use certified print for exact dimensions. Design and materials are subject to change without notice.

# Forged Steel (F22) 2 500 lb Socketweld 1/2" - 2"

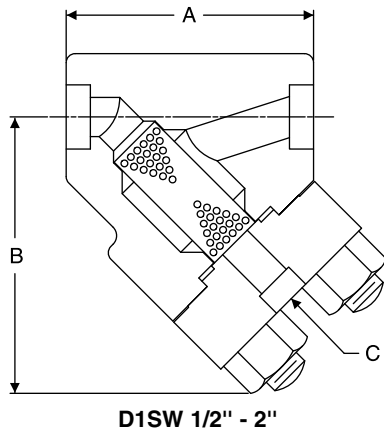

## Pressure/Temperature Rating

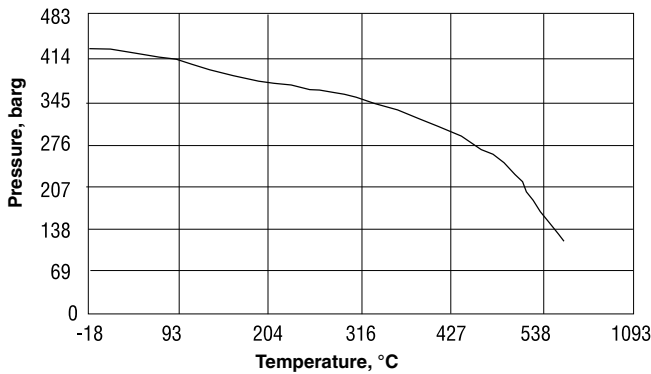

**Table S-385-1. Materials: 2 500 lb Socketweld 1/2" - 2"**

Connection Size in	Body	Screen Retainer	Gasket	Bolting	Standard Screen
1/2", 3/4", 1", 1 1/4", 1 1/2", 2"	ASTM A182 Gr. F22	ASTM A182 Gr. F22	347 SS Spiral Wound Non-asbestos	Studs ASTM A193 Gr. B16 Nuts ASTM A194 Gr. 2H	304 SS 0.045" Perforated †

† Note: Other screen materials available. See page S-379.

**Table S-385-2. Physical Data: 2 500 lb Socketweld 1/2" - 2"**

Connection Size in	Ordering Code, Standard Screen	Weight kg	Dimensions			Maximum Pressure		Screen Retainer Type	Connections
			A mm	B mm	C* in	Saturated Steam bar	38°C non-shock bar		
1/2"	D1SW	12	130	143	1/2"	172	414	Bolted	ANSI B16.11 Socketweld
3/4"									
1"									
1 1/4"	D1SW	25	168	187	1/2"	172	414	Bolted	
1 1/2"									
2"									

\* Socketweld blowdown connections for 1/2" pipe.

Shade indicates products that are CE Marked according to the PED (97/23/EC). All the other sizes comply with the Article 3.3 of the same directive.

**All dimensions and weights are approximate. Use certified print for exact dimensions. Design and materials are subject to change without notice.**



# Cast Stainless Steel (CF8M) 1 500 lb and 600 lb Screwed, Socketweld 1/2" - 3"

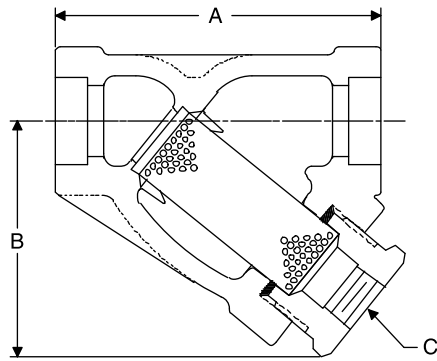

E7SC/E7SW 1/2", 3/4", 1"

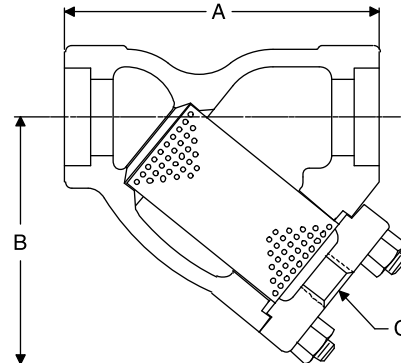

E7SC/E7SW 1 1/4", 1 1/2", 2", 3"

### Pressure/Temperature Rating

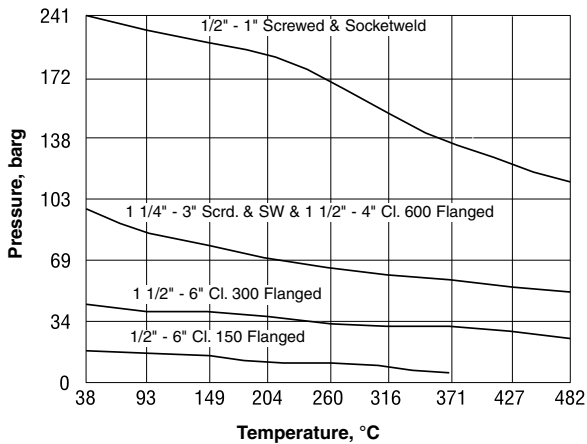

Strainers

**Table S-386-1. Materials: 1 500 lb and 600 lb Screwed or Socketweld 1/2" - 3"**

Connections Size in	Body	Screen Retainer	Gasket	Bolting	Standard Screen
1/2", 3/4", 1"	ASTM A351 Gr. CF8M	ASTM A276	316 SS Flat	N/A	316 SS 0,045" perforated †
1 1/4", 1 1/2", 2"		ASTM A351 Gr. CF8M	304 SS Spiral Wound Non-asbestos	Studs ASTM A193 Gr. B7 Nuts ASTM A194 Gr. 2H	
3"			Non-asbestos	Cap screws ASTM A193 Gr. B7	

† Note: Other screen materials available. See page S-379.

**Table S-386-2. Physical Data: 1 500 lb and 600 lb Screwed or Socketweld 1/2" - 3"**

Connection Size in	Ordering Code Standard Screen		Weight kg	Dimensions			Maximum Pressure		Screen Retainer Type	Connections
	Screwed	SW		A mm	B mm	C in	Saturated Steam bar	38°C non-shock bar		
1/2"	E7SC	E7SW	1,1	95	68	3/8"	144	207	Threaded	ANSI B1.20.1 Screwed
3/4"			1,6	106	75	1/2"				
1"			3,0	127	89					
1 1/4"	E7SC	E7SW	4,0	140	106	1/2"	64	99	Bolted	ANSI B16.11 Socketweld
1 1/2"			5,0	160	122					
2"			9,0	197	143					
3"			23,0	289	208					

Shade indicates products that are CE Marked according to the PED (97/23/EC). All the other sizes comply with the Article 3.3 of the same directive.

**All dimensions and weights are approximate. Use certified print for exact dimensions. Design and materials are subject to change without notice.**

# Cast Stainless Steel (CF8M)

Cl. 150, 300 Flanged 1/2" - 6" and Cl. 600 Flanged 1/2" - 4"

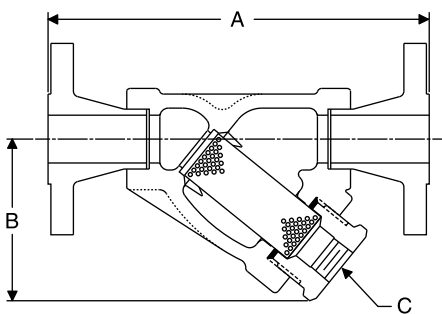

E7FL 1/2", 3/4", 1"

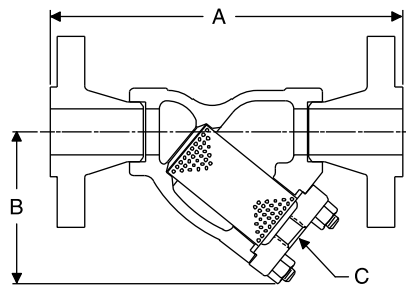

E7FL 1 1/2", 2", 3"

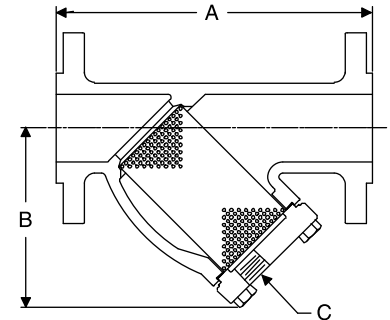

E7FL 4", 6"

**Table S-387-1. Materials: Class 150, 300 Flanged 1/2" - 6" and Class 600 Flanged 1/2" - 4"**

Connection Size in	Body	Screen Retainer	Gasket	Bolting	Standard Screen
1/2", 3/4", 1"	ASTM A351 Gr. CF8M	ASTM A276	316 SS Flat	N/A	316SS 0,045" perforated †
1 1/2", 2"		ASTM A351 Gr. CF8M	304 SS Spiral Wound Non-asbestos	Studs ASTM A193 Gr. B7 Nuts ASTM A194 Gr. 2H	
3", 4", 6"			Non-asbestos	Cap Screws ASTM A193 Gr. B7	

† Note: Other screen materials available. See page S-379.

**Table S-387-2. Physical Data: Class 150, 300 Flanged 1/2" - 6" and Class 600 Flanged 1/2" - 4"**

Connection Size in	Ordering Code, Standard Screen	Weight kg	Dimensions			Maximum Pressure		Screen Retainer Type	Flanges
			A mm	B mm	C in	Saturated Team bar	38°C non-shock bar		
1/2"	E7FL 150	2,3	175	68	3/8"	14	19	Threaded	ANSI B16.5 1/16" RF
3/4"		4,5	187	75	1/2"				
1"		5,0	213	89					
1 1/2"		9,0	257	122					
2"		11,0	292	143					
3"	E7FL 150	25,0	397	208	1 1/4"	14	19	Bolted	
4"		36,0	422	273	1 1/2"				
6"		-	574	387					
1/2"	E7FL 300	3,0	184	68	3/8"	34	50	Threaded	ANSI B16.5 1/16" RF
3/4"		4,3	197	75	1/2"				
1"		6,0	226	89					
1 1/2"	E7FL 300	10,0	273	122	1/2"	34	50	Bolted	
2"		15,0	308	143	1 1/4"				
3"		34,0	416	208					
4"		65,0	438	273					
6"		137,0	597	387					
1/2"	E7FL 600	4,0	195	68	3/8"	64	99	Threaded	ANSI B16.5 1/4" RF
3/4"		4,3	210	75	1/2"				
1"		6,0	238	89					
1 1/2"	E7FL 600	12,0	287	122	1/2"	64	99	Bolted	
2"		14,0	324	143	1 1/4"				
3"		34,0	435	208					
4"		69,0	464	273					

Note: For pressure/temperature ratings, see page S-386.

Shade indicates products that are CE Marked according to the PED (97/23/EC). All the other sizes comply with the Article 3.3 of the same directive.

All dimensions and weights are approximate. Use certified print for exact dimensions. Design and materials are subject to change without notice.



# Cast Bronze 300 lb Screwed 1/2" - 2"

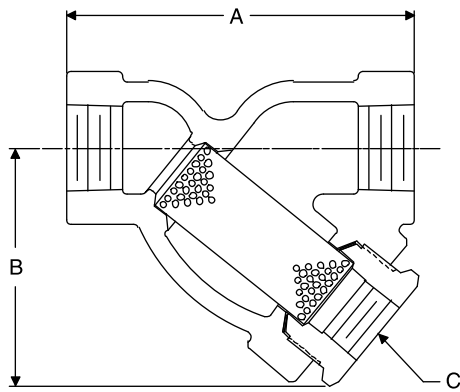

F4SC 1/2"- 2"

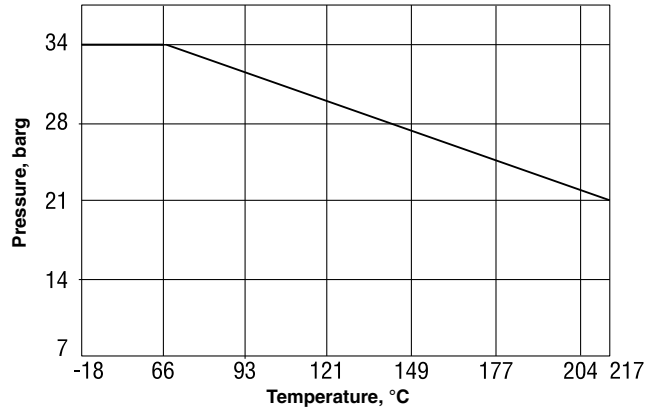

Strainers

Table S-388-1. Materials: 300 lb Screwed 1/2" - 2"

Connection Size in	Body	Screen Retainer	Gasket	Bolting	Standard Screen

† Note: Other screen materials available. See page S-379.

Table S-388-2. Physical Data: 300 lb Screwed 1/2" - 2"

Connection Size in	Ordering Code, Standard Screen	Weight kg	Dimensions			Maximum Pressure		Screen Retainer Type	Connections
			A mm	B mm	C in	Saturated Steam bar	66°C non-shock bar		
1/2"	F4SC	0,68	89	64	3/8"	21	34	Threaded	ANSI B1.20.1 Screwed
3/4"		0,91	102	73					
1"		1,60	121	84					
1 1/4"		2,30	133	102					
1 1/2"		3,40	152	111					
2"	F4SC	5,40	178	140	1/2"	21	34	Threaded	

Shade indicates products that are CE Marked according to the PED (97/23/EC). All the other sizes comply with the Article 3.3 of the same directive.

All dimensions and weights are approximate. Use certified print for exact dimensions. Design and materials are subject to change without notice.



# Water Flow Capacities



**Table S-389-1. Water Flow Capacities in m³/h**

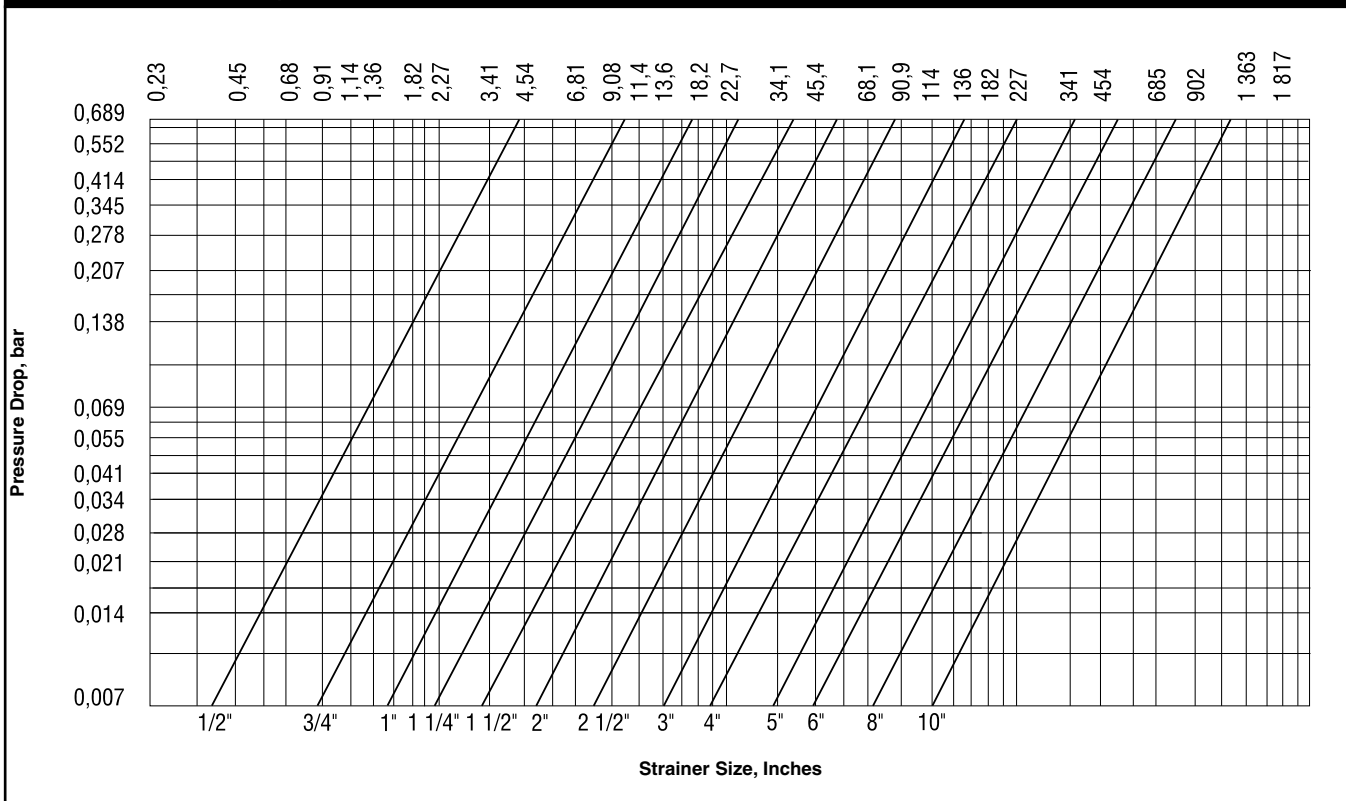

## Armstrong Y-Type Strainers – Master Selection Table

**Table S-389-2. Master Selection Table**

Material	Connections	Sizes in	Pressure - Temperature Ratings	
			Steam, Non-Shock	Cold, Non-Shock
Cast Iron ASTM A48 Class 30	Screwed - 250 lb	1/2" - 3"	17 bar @ 208°C	28 bar @ 66°C
	Class 125 Flanged	2" - 10"	8,6 bar @ 178°C	12 bar @ 66°C
	Class 250 Flanged	2" - 8"	17 bar @ 208°C	28 bar @ 66°C
Cast Carbon Steel ASTM A216 Gr. WCB	Screwed & Socketweld - 900 lb	1/2" - 1"	113 bar @ 321°C	153 bar @ 38°C
	Screwed & Socketweld - 600 lb	1 1/4" - 3"	78 bar @ 294°C	102 bar @ 38°C
	Class 150 Flanged	1/2" - 6"	14 bar @ 199°C	20 bar @ 38°C
	Class 300 Flanged	1/2" - 6"	42 bar @ 254°C	51 bar @ 38°C
Cast Chrome Moly Steel ASTM A217 Gr. WC6	Class 600 Flanged	1/2" - 4"	78 bar @ 294°C	102 bar @ 38°C
	Screwed & Socketweld - 1 500 lb	1/2" - 1"	144 bar @ 339°C	207 bar @ 38°C
	Screwed & Socketweld - 1 500 lb	1 1/4" - 2"	173 bar @ 354°C	248 bar @ 38°C
	Class 1 500 Flanged	1/2" - 1"	144 bar @ 339°C	207 bar @ 38°C
Forged Steel ASTM A182 Gr. F22	Class 1 500 Flanged	1 1/4" - 2"	173 bar @ 354°C	248 bar @ 38°C
	Socketweld - 2 500 lb	1/2" - 2"	172 bar @ 552°C	414 bar @ 38°C
Cast SS ASTM A351 Gr. CF8M	Screwed & Socketweld - 1 500 lb	1/2" - 1"	144 bar @ 339°C	207 bar @ 38°C
	Screwed & Socketweld - 600 lb	1 1/4" - 3"	64 bar @ 281°C	99 bar @ 38°C
	Class 150 Flanged	1/2" - 6"	14 bar @ 197°C	19 bar @ 38°C
	Class 300 Flanged	1/2" - 6"	34 bar @ 242°C	50 bar @ 38°C
Cast Bronze ASTM B62	Class 600 Flanged	1/2" - 4"	64 bar @ 282°C	99 bar @ 38°C
	Screwed - 300 lb	1/2" - 2"	21 bar @ 217°C	34 bar @ 66°C

Strainers

