

## BASKET STRAINER

Nominal Pressure	1.6MPa
Test Medium	Water
Strength Test Pressure	24.0Bar
Seal Test Pressure	17.6Bar
Working Temperature	≤100° C

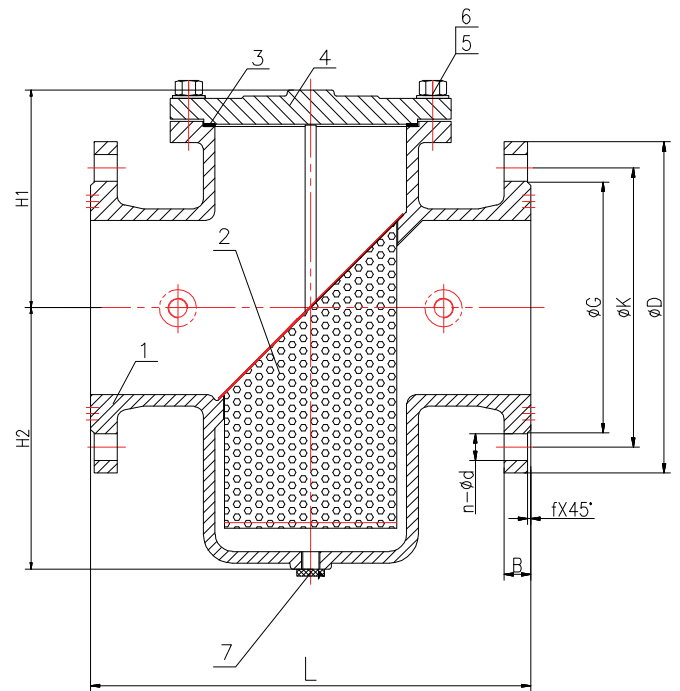

### DIMENSIONS

DN	L	D	K	G	B	f	n-φd	H1	H2
40	207	150	110	88	19	3	4-φ19	114	98
50	207	165	125	100	19	3	4-φ19	114	98
65	210	185	145	119	19	3	4-φ19	129	112
80	251	200	160	135	19	3	8-φ19	142	125
100	292	220	180	156	19	3	8-φ19	165	160
125	334	250	210	186	19	3	8-φ19	173	185
150	378	285	240	212	19	3	8-φ23	165	235
200	475	340	295	268	20	3	12-φ23	215	295
250	511	405	355	318	22	3	12-φ28	325	340
300	667	460	410	373	24.5	3	12-φ28	283	423
350	769	520	470	433	26.5	4	16-φ28	345	585
400	842	580	525	483	28	4	16-φ31	390	590
450	890	640	585	546	30	4	20-φ31	402	628
500	900	715	650	605	31.5	4	20-φ34	441	696
600	1000	840	770	710	36	5	20-φ37	523	834

**PN16**

### STANDARD MATERIALS OF PARTS

NO.	PART	MATERIAL
1	Body	GGG50
2	Screen	SS316
3	Cover Gasket	EPDM
4	Cover	GGG50
5	Bolt	A4
6	Bolt Nut	A4
7	Plug	Galvanized Steel BS1769

