



Quarter-turn Electric Actuator

OM Series

Approvals of ISO 9001, 14001, OHSAS 18001, AEO, CSA, REACH and RoHS

Features:

A. Enclosure:

- IP 67: Waterproof and dust-proof enclosures.
- NEMA 4X: Waterproof and dust-proof enclosures.
- Material: Dry powder coating aluminium alloy.

B. Motor:

- Standard: F insulation class for all models.
- Built-in thermal protection (135°C) prevents motor burning out.

AC motor: 125±5°C / 257±9°F

DC motor: 90±5°C / 194±9°F

C. Position Indicator:

- All models have continuous mechanism position indicator on the top of actuator cover.

D. Manual Override:

- Non-clutch design, the manual operation can be operated without any lever clutch or brake upon power outage.
- When electric motor is operating, manual hand-wheel won't rotate for person safe purpose.

E. Gear Train:

- High alloy steel gear trains provide self-locking function to avoid valve back-drive.
- Gear trains have been already lubricated sufficiently with anti-high temperature lubricant at the factory.

F. Working Conditions:

- Ambient temperature : -30°C ~ +65°C / -22°F ~ +149°F
- The humidity: 30% ~ 95%.

G. Various Options:

- Insulation class for Motor (class H)
- Space heater
- Isolating relay module
- Additional limit switches (2 Units)
- Local control unit (LOCAL / REMOTE, CLOSE/OFF/OPEN)
- Conduit entrance (3/4" PF, 1/2" NPT)
- Torque switches (2 Units)
- Analog signal output
- Modulating controller
- Various voltages
- SS316 enclosure material (OM-1 ~ OM-6).
- Explosion-proof

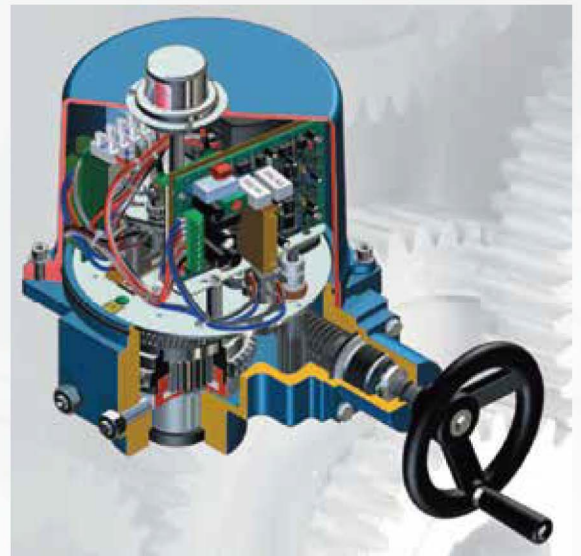

Specification:

Model No	Power (Watts)	Max Torque (N·m)	Speed (Sec/90°)	Weight (Kg)	Manual Override	Mounting Flange (ISO5211)	
OM-1	10	35	12	2	Lever	F03 / F05	
OM-A	10	50	27	3	N/A	F05 / F07	
OM-AM	10	50	27	3	Lever	F05 / F07	
OM-F	60	65	6	11		F07 / F10	
OM-2	40	90	17	11		F07 / F10	
OM-G	60	120	8	11		F07 / F10	
OM-3	40	150	26	11		F07 / F10	
OM-H	60	300	24	17		F07 / F10	
OM-4	80	400	19	20		F10 / F12	
OM-5	80	500	26	20		F10 / F12	
OM-6	80	650	34	20		Handwheel	F10 / F12
OM-7	120	1000	50	32		F12 or F14	
OM-8	120	1500	51	32		F12 or F14	
OM-9	180	2000	62	71	F14 or F16		
OM-10	180	2500	62	71	F14 or F16		
OM-11	180	3000	62	72	F14 or F16		
OM-12	220	3500	62	72	F14 or F16		
OM-13	220	4500	88	106	F16 / F25		

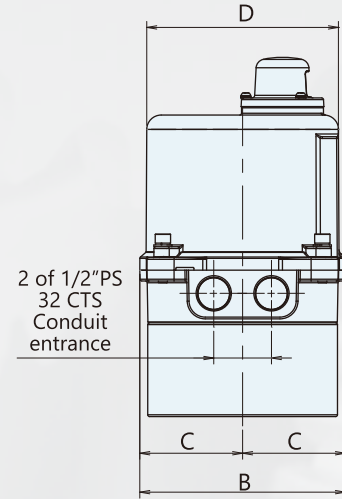
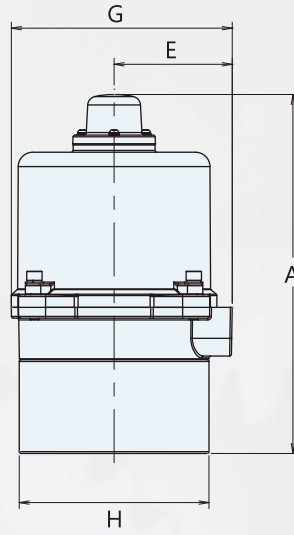

- With modulating controller (option),
A = 232mm (9.133 in)
- No mechanical stops
- No manual override

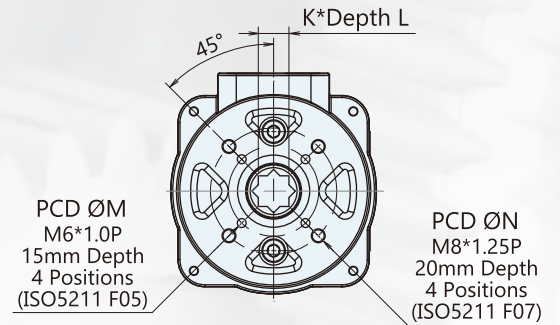

OM-A

Dimension

Unit	A	B	C	D	E	G	H	K	L	M	N
mm	199	114	57	106	65	122	106	17	20	50	70
inch	7.834	4.488	2.244	4.173	2.559	4.803	4.173	0.669	0.787	1.969	2.756

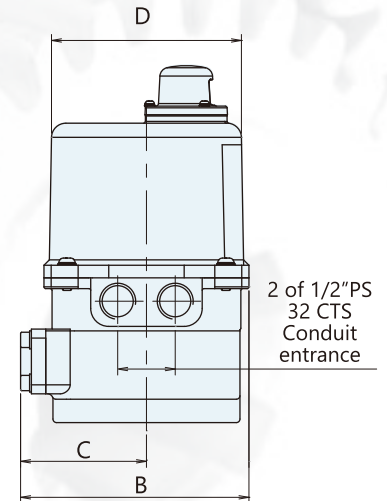
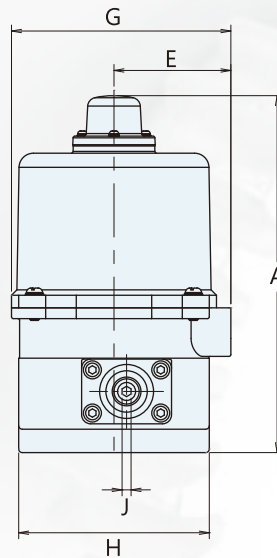

- With modulating controller (option),
A = 232mm (9.133 in)
- No mechanical stops
- Recommend for Manual override:
5mm Hex wrench

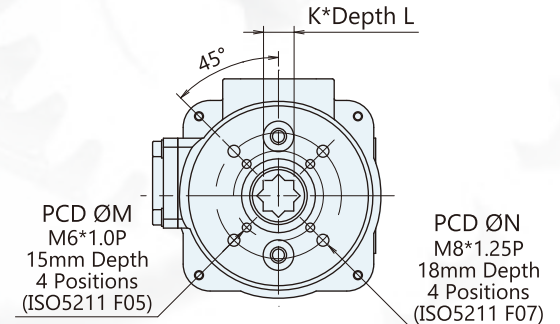

OM-AM

Dimension

Unit	A	B	C	D	E	G	H	J	K	L	M	N
mm	199	127	70	106	65	122	102	5	17	20	50	70
inch	7.834	5	2.756	4.173	2.559	4.803	4.016	0.197	0.669	0.787	1.969	2.756

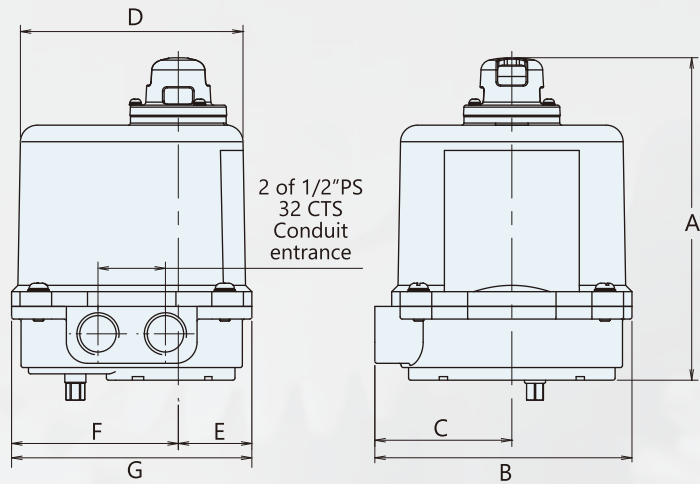

- With modulating controller (option),
A = 186mm (7.323 in)
- No mechanical stops
- Recommend for Manual override:
8mm Open-end wrench

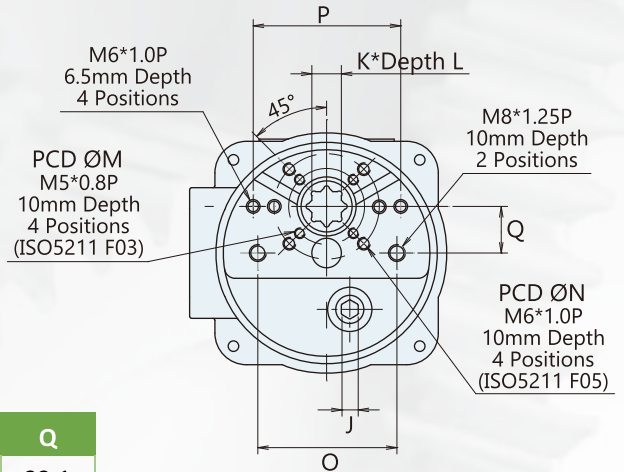

OM-1

Dimension

Unit	A	B	C	D	E	F	G
mm	153	122	65	106	35	79	114
inch	6.024	4.803	2.559	4.173	1.378	3.11	4.488

Unit	J	K	L	M	N	O	P	Q
mm	8	14	17	36	50	66	70	22.1
inch	0.315	0.551	0.669	1.417	1.969	2.598	2.756	0.87

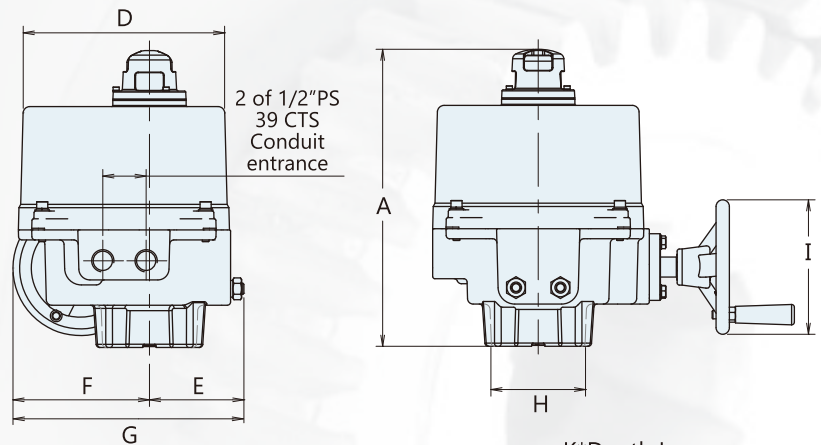

- With DC motor (option)
A = 302mm (11.890 in)
(Apply to DC model
or 75% duty cycle)
- With torque switch (option),
B = 363mm (14.291 in)
C = 268mm (10.551 in)

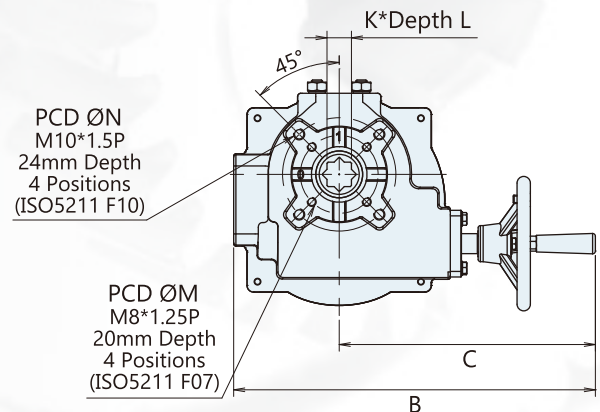

OM-2 ~ OM-3

Dimension

Unit	A	B	C	D	E	F	G	H	I	K	L	M	N
mm	268	326	231	181	85	123	208	85	121	22	30	70	102
inch	10.551	12.835	9.094	7.126	3.346	4.843	8.189	3.346	4.764	0.866	1.181	2.756	4.016

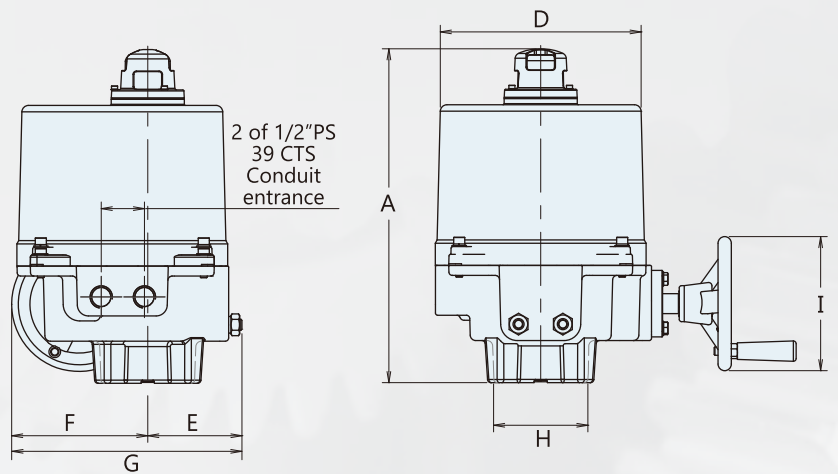

- With torque switch (option),
B = 363mm (14.291 in)
C = 268mm (10.551 in)

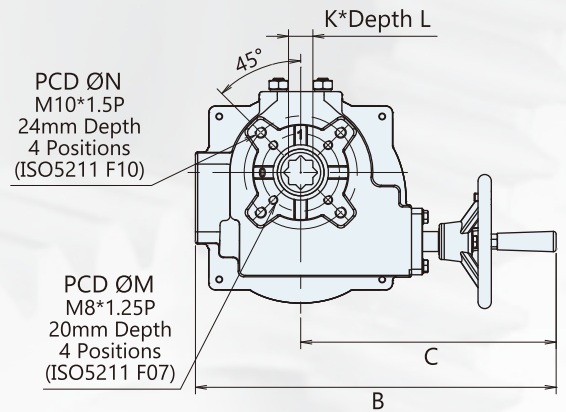

OM-F & OM-G

Dimension

Unit	A	B	C	D	E	F	G	H	I	K	L	M	N
mm	302	326	231	181	85	123	208	85	121	22	30	70	102
inch	11.89	12.835	9.094	7.126	3.346	4.843	8.189	3.346	4.764	0.866	1.181	2.756	4.016

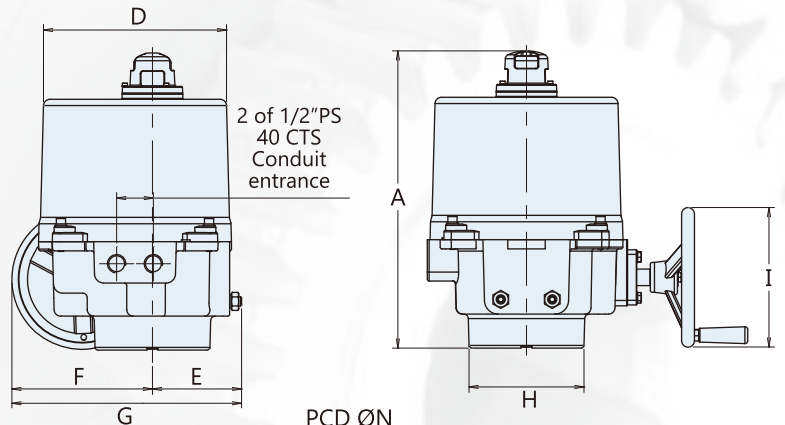

- With torque switch (option),
B = 400mm (15.748 in)
C = 292mm (11.496 in)

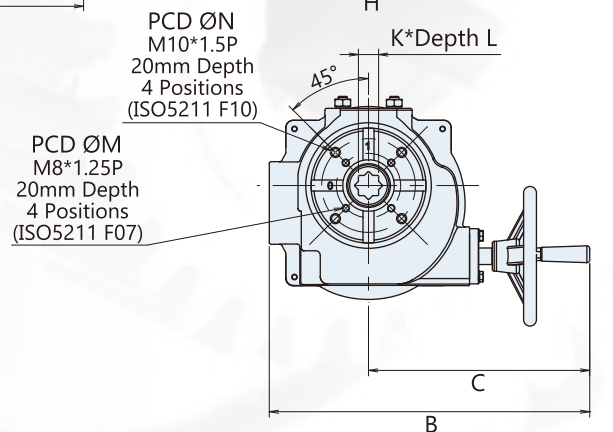

OM-H

Dimension

Unit	A	B	C	D	E	F	G	H	I	K	L	M	N
mm	324	349	241	199	97	153	250	125	152	22	30	70	102
inch	12.756	13.74	9.488	7.835	3.818	6.024	9.842	4.921	5.984	0.866	1.181	2.756	4.016



- With torque switch (option),
B = 458mm (18.031 in)
C = 341mm (13.425 in)

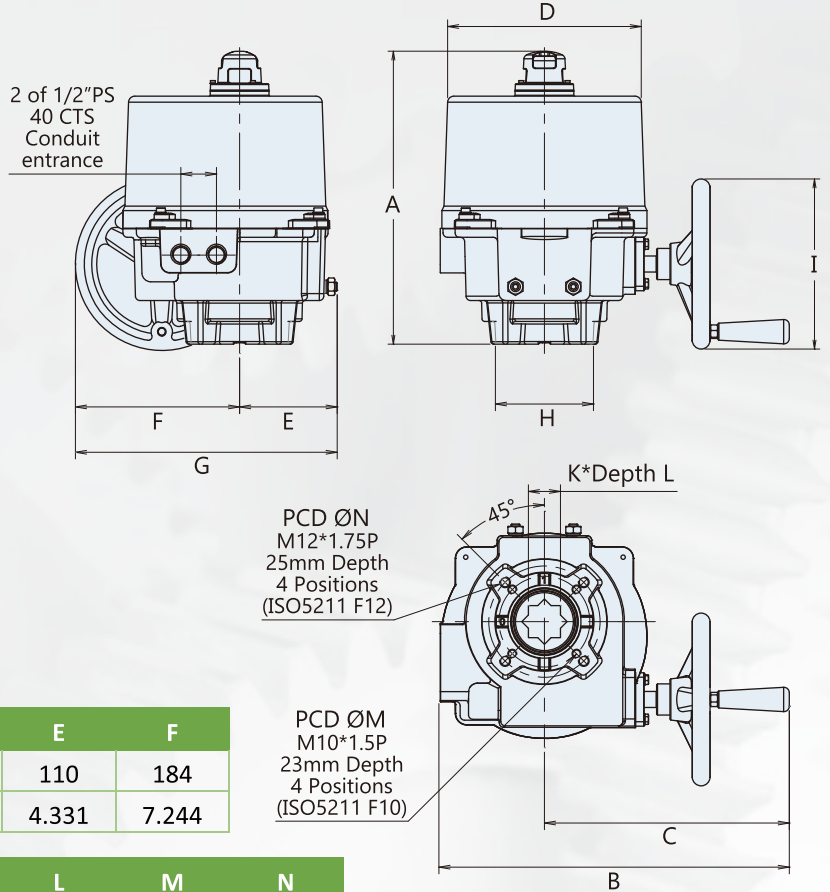

OM-4 ~ OM-6

Dimension

Unit	A	B	C	D	E	F
mm	330	392	275	217	110	184
inch	12.992	15.433	10.827	8.543	4.331	7.244

Unit	G	H	I	K	L	M	N
mm	294	110	191	36	40	102	125
inch	11.575	4.331	7.52	1.417	1.547	4.016	4.921



- With torque switch (option),
B = 435mm (17.126 in)
C = 315mm (12.402 in)
- Optional mounting flange size:
ISO 5211 F12 (M12*1.75P)

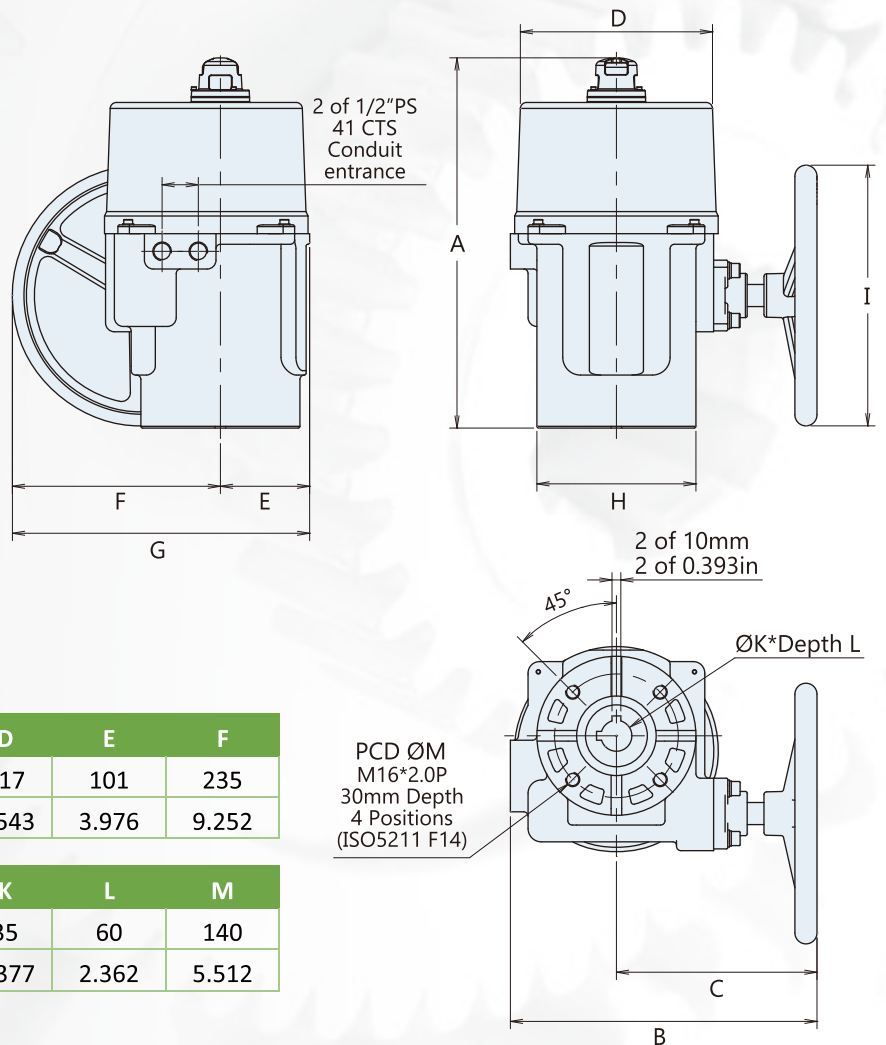

OM-7 ~ OM-8

Dimension

Unit	A	B	C	D	E	F
mm	419	347	227	217	101	235
inch	16.496	13.661	8.937	8.543	3.976	9.252

Unit	G	H	I	K	L	M
mm	336	180	295	35	60	140
inch	13.228	7.087	11.614	1.377	2.362	5.512



- With torque switch (option),
B = 459mm (18.071 in)
C = 288mm (11.339 in)
- Optional mounting flange size:
ISO 5211 F14 (M16*2.0P)

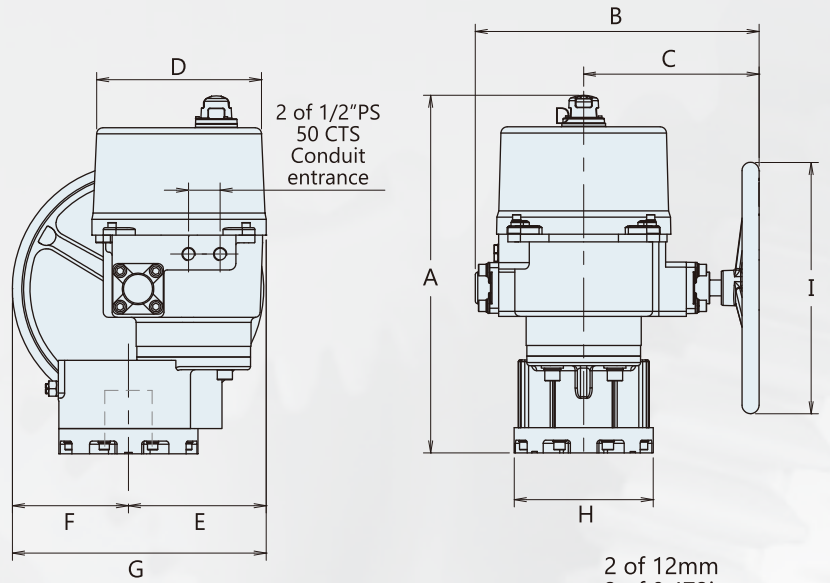

OM-9 ~ OM12

Dimension

Unit	A	B	C	D	E	F
mm	566	449	278	261	218	184
inch	22.283	17.677	10.945	10.276	8.583	7.244

Unit	G	H	I	K	L	M
mm	402	220	398	75	100	165
inch	15.827	8.661	15.669	2.952	3.937	6.496

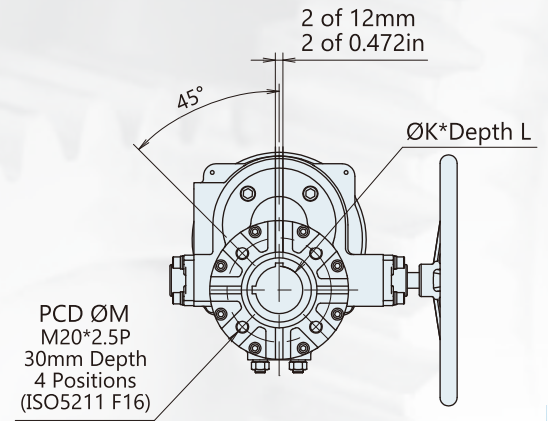

- With torque switch (option),
B = 472mm (18.583 in)
C = 292mm (11.496 in)

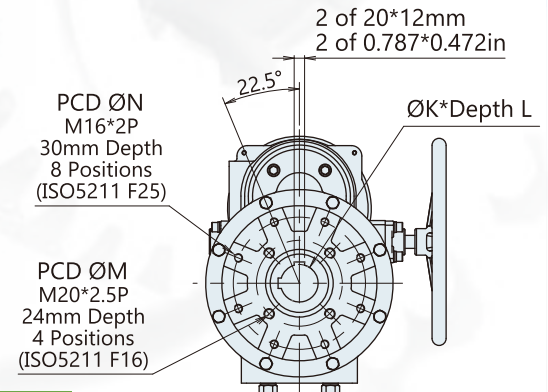
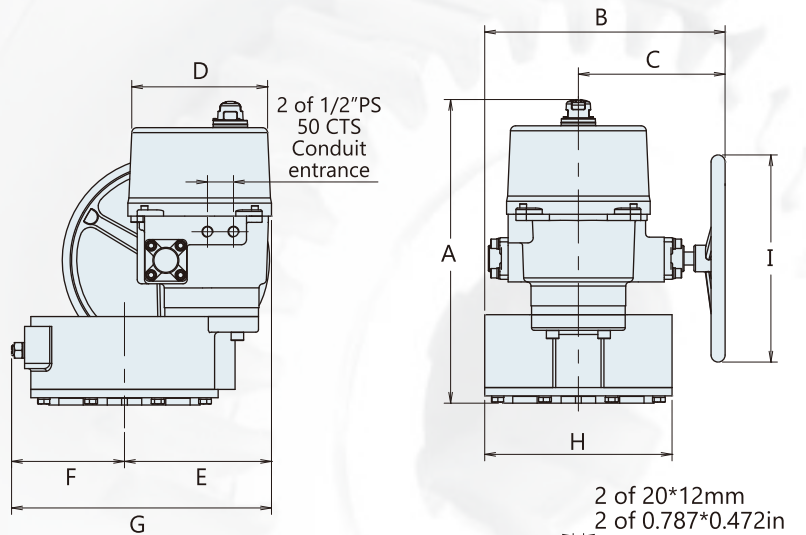

OM-13

Dimension

Unit	A	B	C	D	E	F
mm	584	462	282	261	283	217
inch	22.992	18.189	11.102	10.276	11.142	8.543

Unit	G	H	I	K	L	M	N
mm	500	360	398	72	110	165	254
inch	19.685	14.173	15.669	2.834	4.33	6.496	10

Optional Items

Torque switches



Adjustable cam activated torque switches to provide over-load protection. It must be ordered with actuator and installed and calibrated at the factory. It can only apply to OM-2~13, OM-F, OM-G, and OM-H



OM-1, OM-A & OM-AM
(1K Ω or 5K Ω)



OM-2~13, OM-F, OM-G & OM-H
(1K Ω or 5K Ω)

Potentiometer unit

It is synchronous turn with transmission shaft, and it can provide feedback signal for position indicator and ect.

Motor

Insulation class H.

Analog signal output

It can show the position by signal output.
Analog signal output: 0-20mA, 4-20mA, 0-5V, 0-10V, 1-5V & 2-10V.



OM-1, OM-A & OM-AM



OM-2~13, OM-F, OM-G & OM-H

Isolating relay module

It must be installed when using one control switch to operate two or more actuators.



OM-1, OM-A & OM-AM



OM-2~13, OM-F, OM-G & OM-H

Modulating controller

A proportional control unit.
Analog signal input : 4-20mA, 1-5V, 2-10V
Analog signal output : 4-20mA, 2-10V

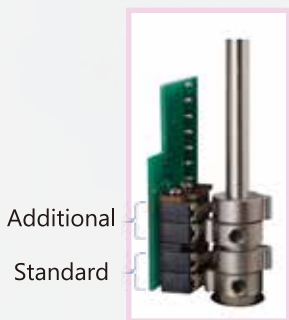

Additional
Standard

OM-1, OM-A & OM-AM



Additional
Standard

OM-2~13, OM-F, OM-G & OM-H

Additional limit switches

Two additional limit switches are optional for fully-open and fully-closed position feedback.



OM-1, OM-A & OM-AM
The extended duty cycle: 75%



OM-1~8 & OM-H
The extended duty cycle: 75%
OM-9~13
The extended duty cycle: 50%

Extended duty cycle controller (IEC standard)

When the working duty cycle over the standard 30%, this option is suggested for extending duty cycle.

Optional Items



Space heater

A space heater keeps the component parts of the actuator dry and prevents the condensation for low temperature and humidity.

It's not recommended if the ambient temperature is over 35°C / 95°F.



Heater thermostat

A heater thermostat can switch the space heater off when the temperature inside the actuator is higher than 25±5°C / 77±9°F.

Voltages

125VDC, 575VAC/3PH and 208VAC/3PH etc.

Conduit entrance

Standard: 1/2"PS

Optional: 3/4"PF, 3/4"NPT, 1/2"NPT, M20



Junction box

It can be directly wired through the junction box without removing the cover of actuators.



Local control unit

The controlling rotary switches include:
LOCAL/REMOTE & CLOSE/OFF/OPEN
IP rating: IP65
Optional: IP67



Chain Wheel

It converts the handwheel manual override to a chain driving override.

The option is available for OM-2~13, OM-F, OM-G & OM-H



Enclosure material

The optional SS316 material is available for OM-1~OM-6.

Optional Items

Hazardous Area Enclosures - The certificates for Explosion-proof Actuators -

- TS Taiwan Hazardous Area Certification



- CNEx China Hazardous Area Certification



- ATEX Certification



II 2GD

Ex db IIB T4 Gb

Ex tb IIIC T130°C Db

TA = -30°C ≤ Tamb ≤ +70°C

(-22°F ≤ Tamb ≤ + 158°F)

Standards: IEC 60079-0, IEC 60079-1, IEC 60079-31

- IECEx International Certification



Ex db IIB T4 Gb

Ex tb IIIC T130°C Db

TA = -30°C ≤ Tamb ≤ +70°C

(-22°F ≤ Tamb ≤ + 158°F)

Standards: EN60079-0, EN60079-1, EN60079-31

- CSA Hazardous Area Certification



Class I, Division 1, Groups C, D T4

Class II, Division 1, Groups E, F, G T130°C

TA = -30°C ≤ Tamb ≤ +70°C

(-22°F ≤ Tamb ≤ + 158°F)

Standards: CAN / CSA-C22.2 No.0-10, CSA C22.2 No.30-M1986,
CSA C22.2 No.25-17, FM 3600, FM 3615, FM3616

Ex, db, IIB, T4 Gb (For Canada)

Class I, Zone 1, AEx db, IIB, T4 Gb (For US)

Ex, tb, IIIC, T130°C, Db (For Canada)

Class II, Zone 21, AEx tb, IIIC, T130°C, Db (For US)

TA = -30°C ≤ Tamb ≤ +70°C

(-22°F ≤ Tamb ≤ + 158°F)

Standards: CAN / CSA-C22.2 No.0-10, CAN / CSA-C22.2 No.60079-0,
CAN / CSA-C22.2 No.60079-1, CAN / CSA-C22.2 No.60079-31,
UL 60079-0, UL 60079-1, UL 60079-31



The Rating for Hazardous Area Enclosures: IP 68



vanco

W 24 th Street, San Antonio Heights, Ontario, Canada

www.vancoflowcontrol.com