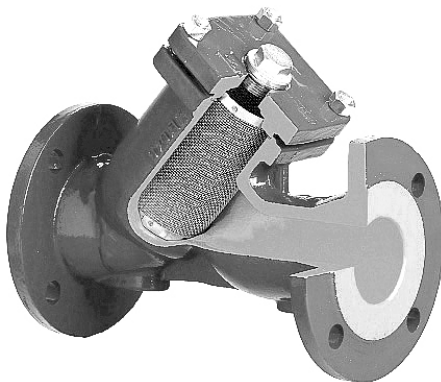



**Fig 33K in Cast Iron, Fig 34K in Carbon Steel and
Fig 3716K in SG Iron
Flanged Strainer**

Installation and Maintenance Instructions



1. Safety information
2. General product information
3. Installation
4. Commissioning
5. Operation
6. Fault finding
7. Maintenance
8. Spare parts

1. Safety information

Safe operation of these products can only be guaranteed if they are properly installed, commissioned, used and maintained by qualified personnel (see Section 1.11) in compliance with the operating instructions. General installation and safety instructions for pipeline and plant construction, as well as the proper use of tools and safety equipment must also be complied with.

1.1 Intended use

Referring to the Installation and Maintenance Instructions, name-plate and Technical Information Sheet, check that the product is suitable for the intended use/application.

The products listed below comply with the requirements of the European Pressure Equipment Directive 2014/68/EU and carry the **CE** mark when so required. It should be recalled that products classified in the "SEP" category for the provision of the Directive should not be marked.

The products fall within the following Pressure Equipment Directive categories:

Prodotto		Group 1 Gases	Group 2 Gases	Group 1 Liquids	Group 2 Liquids	
Fig 33K Fig 3716K	PN16	DN15 ÷ DN25	SEP	SEP	SEP	
		DN32	1	SEP	SEP	
		DN40	1	SEP	SEP	
		DN50	1	SEP	SEP	
		DN65	2	1	SEP	SEP
		DN80	2	1	SEP	SEP
		DN100	2	1	SEP	SEP
		DN125	2	1	SEP	SEP
		DN150	2	1	2	SEP
		DN200	2	1	2	SEP
Fig 34K	PN40	DN15 ÷ DN25	SEP	SEP	SEP	
		DN32	2	SEP	SEP	
		DN40	2	1	SEP	SEP
		DN50	2	1	SEP	SEP
		DN65	2	1	2	SEP
		DN80	2	1	2	SEP
		DN100	3	2	2	SEP
		DN125	3	2	2	SEP
		DN150	3	3	2	SEP
		DN200	3	3	2	SEP

-
- I) These products have been specifically designed for use on propane or methane comprised in Group 1 of the above-mentioned Pressure Equipment Directive. The products' use on steam, air or water/condensate or other fluids may be possible but, if this is contemplated, Spirax Sarco should be contacted to confirm the suitability of the product for the application being considered.
 - II) Check material suitability, pressure and temperature and their maximum and minimum values. If the maximum operating limits of the product are lower than those of the system in which it is being fitted, or if malfunction of the product could result in a dangerous overpressure or over-temperature occurrence, ensure a safety device is included in the system to prevent such over-limit situations.
 - III) Determine the correct installation situation and direction of fluid flow.
 - IV) Spirax Sarco products are not intended to withstand external stresses that may be induced by any system to which they are fitted. It is the responsibility of the installer to consider these stresses and take adequate precautions to minimise them.
 - V) Remove protection covers from all connections and protective film from all name-plates, where appropriate, before installation on steam or other high temperature applications.

1.2 Access

Ensure safe access and if necessary a safe working platform (suitably guarded) before attempting to work on the product. Arrange suitable lifting gear if required.

1.3 Lighting

Ensure adequate lighting, particularly where detailed or intricate work is required.

1.4 Hazardous liquids or gases in the pipeline

Consider what is in the pipeline or what may have been in the pipeline at some previous time. Consider: flammable materials, substances hazardous to health, extremes of temperature.

1.5 Hazardous environment around the product

Consider: explosion risk areas, lack of oxygen (e.g. tanks, pits), dangerous gases, extremes of temperature, hot surfaces, fire hazard (e.g. during welding), excessive noise, moving machinery.

1.6 The system

Consider the effect on the complete system of the work proposed. Will any proposed action (e.g. closing isolation valves, electrical isolation) put any other part of the system or any personnel at risk? Dangers might include isolation of vents or protective devices or the rendering ineffective of controls or alarms. Ensure isolation valves are turned on and off in a gradual way to avoid system shocks.

1.7 Pressure systems

Ensure that any pressure is isolated and safely vented to atmospheric pressure. Consider double isolation (double block and bleed) and the locking or labelling of closed valves. Do not assume that the system has depressurised even when the pressure gauge indicates zero. .

1.8 Temperature

Allow time for temperature to normalise after isolation to avoid danger of burns.

1.9 Tools and consumables

Before starting work ensure that you have suitable tools and/or consumables available. Use only genuine Spirax Sarco replacement parts.

1.10 Protective clothing

Consider whether you and /or others in the vicinity require any protective clothing to protect against the hazards of, for example, chemicals, high / low temperature, radiation, noise, falling objects, and dangers to eyes and face.

1.11 Permits to work

All work must be carried out or be supervised by a suitably competent person. Installation and operating personnel should be trained in the correct use of the product according to the Installation and Maintenance Instructions.

Where a formal 'permit to work' system is in force it must be complied with. Where there is no such system, it is recommended that a responsible person should know what work is going on and, where necessary, arrange to have an assistant whose primary responsibility is safety.

Post 'warning notices' if necessary.

1.12 Handling

Manual handling of large and/or heavy products may present a risk of injury.

Lifting, pushing, pulling, carrying or supporting a load by bodily force can cause injury particularly to the back.

You are advised to assess the risks taking into account the task, the individual, the load and the working environment and use the appropriate handling method depending on the circumstances of the work being done.

1.13 Residual hazards

In normal use the external surface of the product may be very hot. If used at the maximum permitted operating conditions the surface temperature of some products may reach temperatures of 538°C (1000.4°F).

Many products are not self-draining. Take due care when dismantling or removing the product from an installation (refer to 'Maintenance instructions').

1.14 Freezing

Provision must be made to protect products which are not self-draining against frost damage in environments where they may be exposed to temperatures below freezing point.

1.15 Disposal

Unless otherwise stated in the Installation and Maintenance Instructions, this product is recyclable and no ecological hazard is anticipated with its disposal providing due care is taken.

1.16 Returning products

Customers and stockists are reminded that under EC Health, Safety and Environment Law, when returning products to Spirax Sarco they must provide information on any hazards and the precautions to be taken due to contamination residues or mechanical damage which may present a health, safety or environmental risk.

This information must be provided in writing including Health and Safety data sheets relating to any substances identified as hazardous or potentially hazardous.

1.17 Working safely with cast iron products on steam

Cast iron products are commonly found on steam and condensate systems. If installed correctly using good steam engineering practices, it is perfectly safe. However, because of its mechanical properties, it is less forgiving compared to other materials such as SG iron or carbon steel. The following are the good engineering practices required to prevent waterhammer and ensure safe working conditions on a steam system.

Safe Handling

Cast Iron is a brittle material. If the product is dropped during installation and there is any risk of damage the product should not be used unless it is fully inspected and pressure tested by the manufacturer.

Please remove label before commissioning

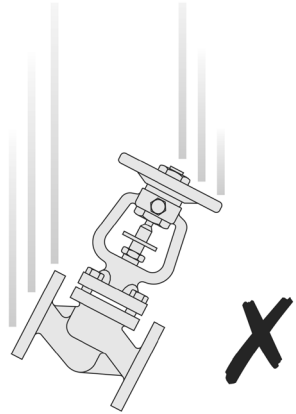

Prevention of water hammer

Steam trapping on steam mains:

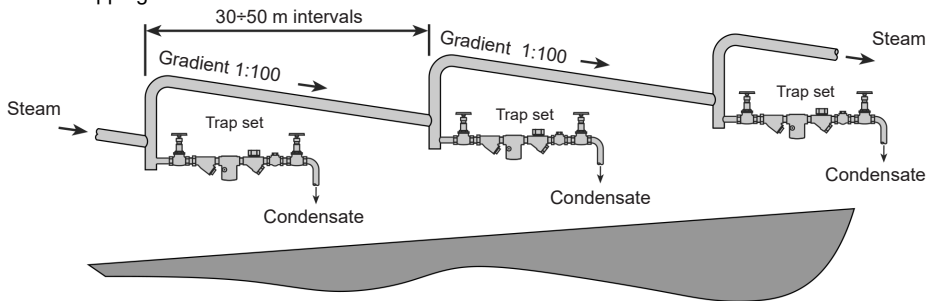

Steam Mains - Do's (✓) and Dont's (X):

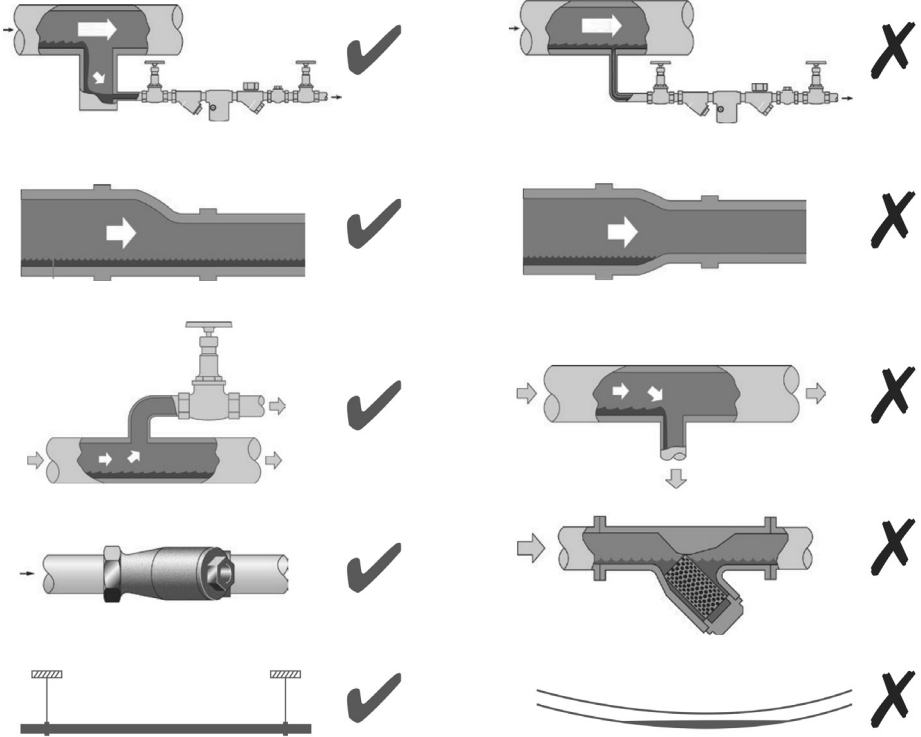

Prevention of tensile stressing

Pipe misalignment:

Installing products or re-assembling after maintenance:



Do not over tighten.
Use correct torque figures.

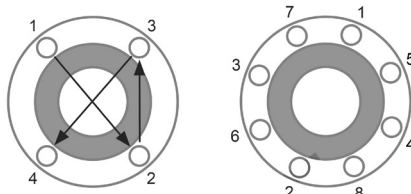

Flange bolts should be gradually tightened across diameters to ensure even load and alignment.

Thermal expansion:

Examples showing the use of expansion bellows. It is highly recommended that expert advise is sought from the bellows manufacturer.

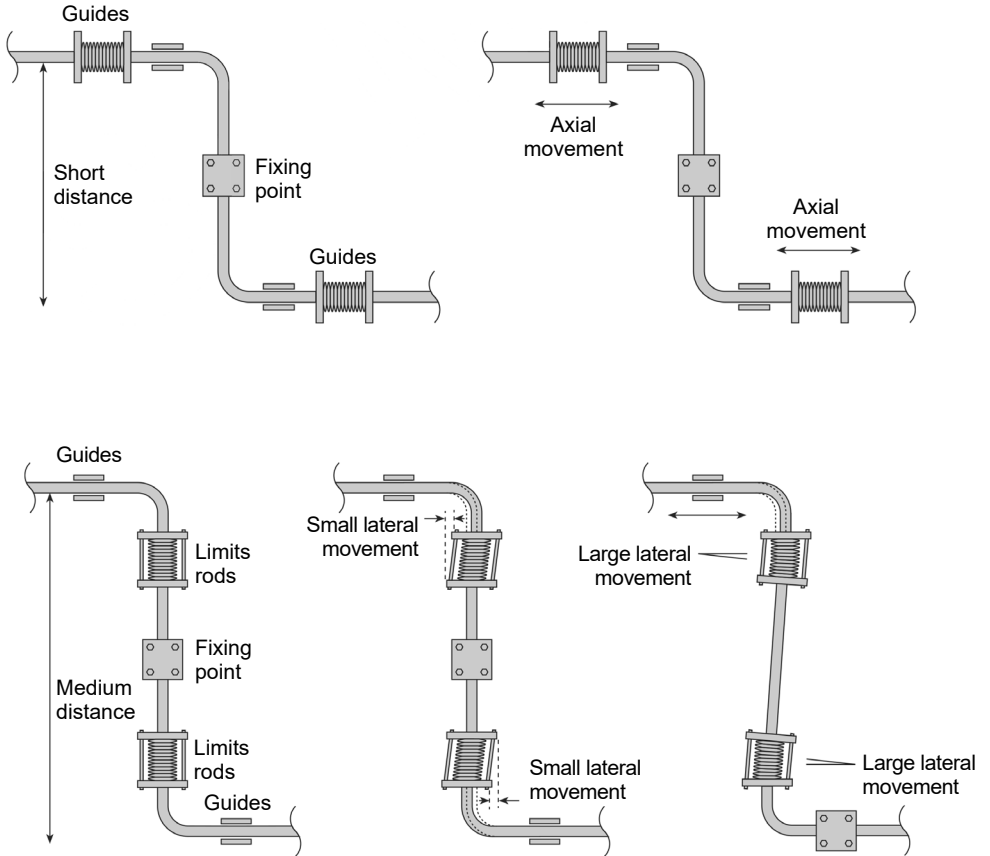

2. General product information

2.1 General description

The products detailed below are Y-type strainers with flanged connections. They are designed to protect other pipeline items from damage due to debris and dirt flowing inside the system stream. Most of the standard Y-type strainer screens are in stainless steel with perforation 1.0 + 1.6 mm. For other Y-type strainer screen models see Section 2.2.

Note: For additional information see the relevant Technical Specification.

Strainer	Body material	Limiting design conditions	DN	Technical specification
Fig 33K	Cast iron	PN16	15 - 200	3C.300
Fig 34K	Carbon steel	PN40	15 - 200	3C.305
Fig 3716K	SG iron	PN16	15 - 200	3C.310

2.2 Optional extras

Stainless steel strainer screen	Perforations	1,0 mm (DN15+DN50)
		1,25 mm (DN65 e DN80)
		1,6 mm (DN100+DN200)
	Mesh	15, 28, 45, 100

Blowdown or Drain Valve inserting connection

The cap comes already drilled and tapped to the following sizes to enable a blowdown or drain valve to be fitted (valves available on request).

Strainer DN	Drain connection
15+20	3/8"
25+32	3/4"
40+80	1"
80+200	1 1/2"

2.3 Pressure - temperature limits

Fig 33K

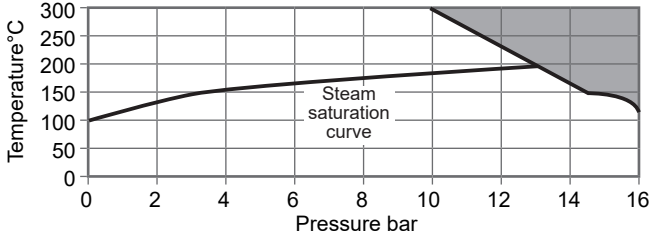

 The product must not be used in this region

Body design conditions	PN16	
PMA Maximum allowable pressure	16 bar	
TMA	Maximum allowable temperature	300°C
	Minimum allowable temperature	-10°C
PMO Maximum operating pressure for saturated steam service	13 bar	
Maximum operating temperature	300°C	
Minimum operating temperature	-10°C	
Designed for a maximum cold hydraulic test pressure of 24 bar		

Fig 34K

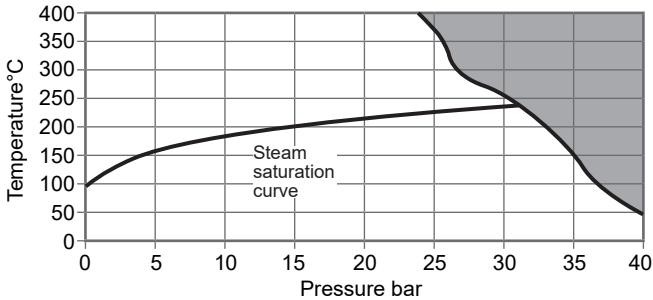

 The product must not be used in this region

Body design conditions	PN40	
PMA Maximum allowable pressure	40 bar	
TMA	Maximum allowable temperature	400°C
	Minimum allowable temperature	-20°C
PMO Maximum operating pressure for saturated steam service	31 bar	
Maximum operating temperature	400°C	
Minimum operating temperature	-20°C	
Designed for a maximum cold hydraulic test pressure of 60 bar		

Fig 3716K

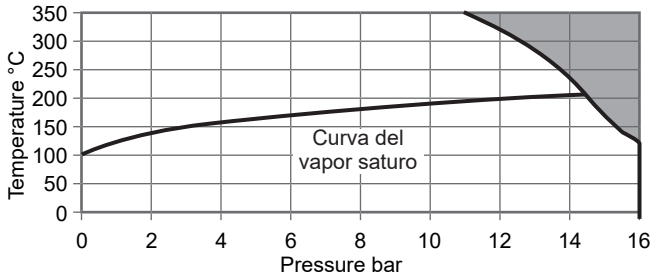

 The product must not be used in this region

Body design conditions	PN16
PMA Maximum allowable pressure	16 bar
TMA Maximum allowable temperature	350°C
TMA Minimum allowable temperature	-10°C
PMO Maximum operating pressure for saturated steam service	14,7 bar
Maximum operating temperature	350°C
Minimum operating temperature	-10°C
Designed for a maximum cold hydraulic test pressure of 24 bar	

2.4 Materials - Body marking information

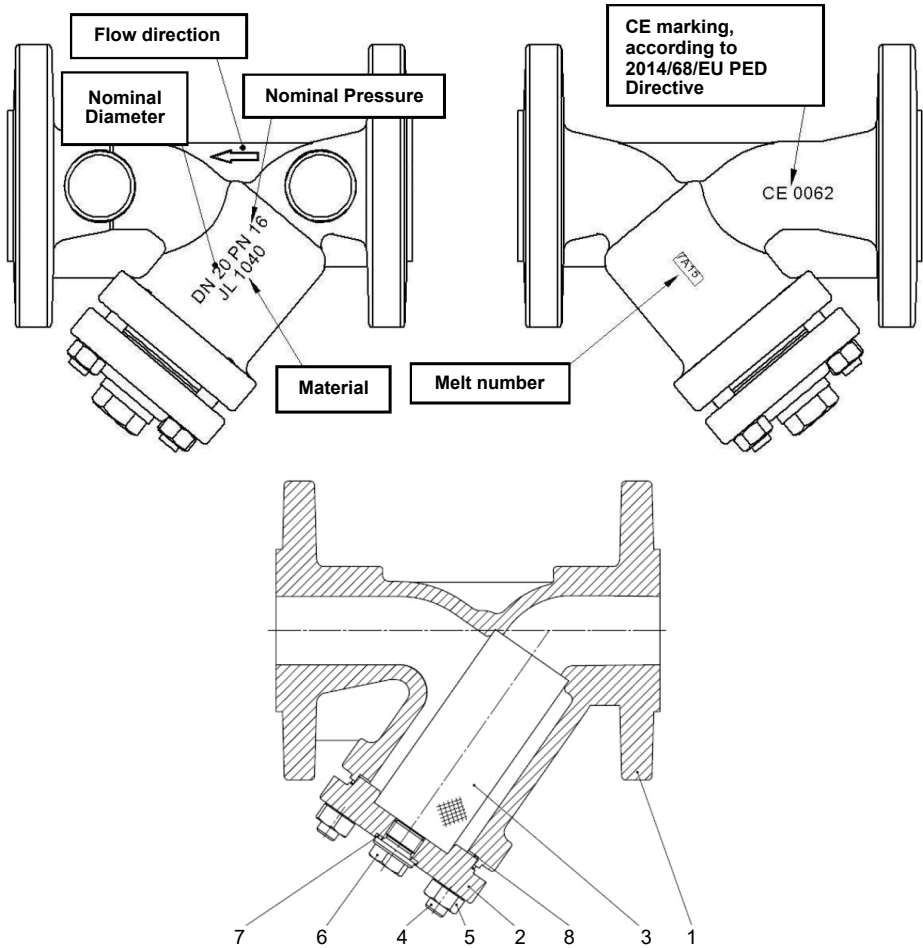

Fig 33K Strainer

N° Part	Material	Designation
1 Body	Cast iron	EN-GJL-250 JL1040
2 Cap	Cast iron	EN-GJL-250 JL1040
3 Strainer screen	Stainless steel	AISI 304
4 Bolts	Carbon steel	8.8-A2A
5 Hex nut	Carbon steel	8-A2A
6 Drain plug	Steel	C35E
7 Tap gasket	Stainless steel	A4 1.4571
8 Cap gasket	Reinforced exfoliated graphite	

Modello Fig 34K

N° Part	Material	Designation
1 Body	Acciaio al carbonio	GP240GH 1.0619
2 Cap	Acciaio al carbonio	GP240GH 1.0619
3 Strainer screen	Stainless steel	AISI 304
4 Stud	Steel	25CrMo4
5 Hex nut	Steel	C35E
6 Drain/Blowdown tap	Steel	C35E
7 Tap gasket	Stainless steel	A4 1.4571
8 Cap gasket	Reinforced exfoliated graphite	

Modello Fig 3716K

N° Parts	Material	Designation
1 Body	SG iron	EN-GJS-400-18 JS1025
2 Cap	SG iron	EN-GJS-400 -18 JS1025
3 Strainer screen	Stainless steel	AISI 304
4 Stud	Stainless steel	A2-70
5 Hex nut	Stainless steel	A2-70
6 Drain/Blowdown tap	Steel	C35E
7 Tap gasket	Stainless steel	A4 1.4571
8 Cap gasket	Reinforced exfoliated graphite	

3. Installation

Note: Before actioning any installation observe the 'Safety Information' in Section 1.

Referring to the installation and Maintenance Instructions, name-plate and Technical Information Sheet, check that the product is suitable for the intended installation:

- 3.1** Check materials, pressure and temperature and their maximum values. If the maximum operating limit of the product is lower than that of the system in which it is being fitted, ensure that a safety device is included in the system to prevent over-pressurisation.
- 3.2** Determine the correct installation situation and the direction of fluid flow.
- 3.3** Remove protection covers from all connections and protective film from all name-plates, where appropriate, before installation on steam or other high temperature applications.
- 3.4** Strainers can be fitted on liquid or steam/gas systems in either horizontal pipework or vertical pipework where the flow is downward. In a horizontal line on steam/gases applications the strainer pocket (Y) should be in the horizontal plane as this reduces the possibility of waterhammer/condensation stagnation. On liquid systems, the strainer pocket should point downwards.
- 3.5** Strainers may be insulated if required.

4. Commissioning

After installation or maintenance always ensure that the system is fully functional. Carry out tests on any alarms or protective devices.

5. Operation

Strainers are passive devices designed to prevent the passage of dirt and impurities within the flow having dimensions larger than the screen holes. Pressure drop across the strainer will increase as the strainer screen becomes clogged. A regular strainer cleaning and drainage is recommended to keep the screen clean.

6. Fault finding

Symptom	Possible cause	Remedy
No flow through strainer	Blocked screen	Clean or replace the strainer screen (See Section 7.2)
	System is isolated/blocked	Check isolation valves
Pressure drop is increased across the strainer	Strainer screen is blocked up	Clean or replace the strainer screen (See Section 7.2)

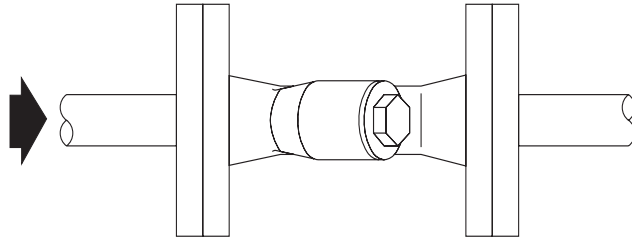

Strainer installed on a steam or gas line

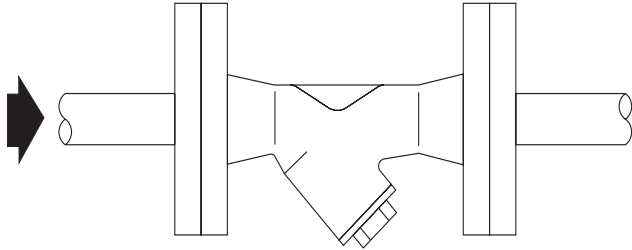

Strainer installed on a liquid line

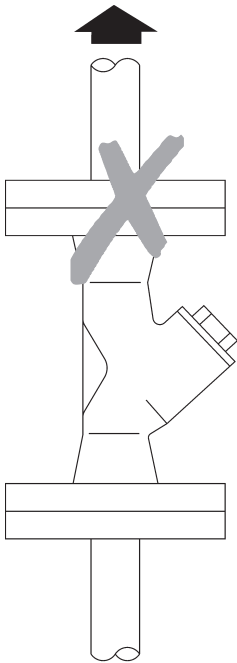

**Stream flowing upwards
incorrect installation**

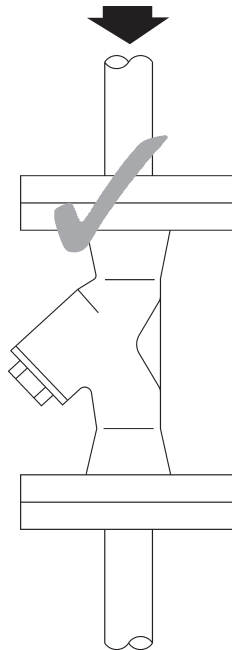

**Stream flowing downwards
correct installation**

7. Maintenance

Note: Before actioning any maintenance programme, observe the 'Safety information' in Section 1.

Warning

The cover gasket contains a thin stainless steel support ring which may cause physical injury if not carefully handled and disposed.

7.1 General information

Before undertaking any maintenance on the strainer, it must be isolated from both the supply line and return line and any pressure allowed to safely normalise to atmosphere. The trap should then be allowed to cool. When reassembling, ensure that all joint faces are clean and undamaged.

7.2 How to clean or replace the strainer screen:

For identification of parts refer to Section 8, 'Spare parts'

- Remove the strainer cap. On most sizes, up to DN25 the cap has to be simply unscrewed. On all other sizes the cap is retained by bolts / nuts. The number of bolts / nuts used will depend on the strainer size, material of construction and design rating.
- Once the cap is removed the strainer screen can be simply disassembled.
- Clean the strainer screen or replace it with a new one if necessary.
- Reinsert the strainer screen by pushing it into its seat.
- Always fit a new strainer cap gasket ensuring the jointing faces are clean.
- Replace the strainer cap using anti-seize assembly paste on bolts/nuts, then tighten to the recommended torque (referring to the relevant Table, '7.3 Recommended tightening torques').
- Before final torque is applied, ensure that the nuts are tightened evenly.
- Check for leaks.

7.3 Recommended tightening torques

Screw	N m
M8	15 - 20 Nm
M10	35 - 40 Nm
M12	65 - 70 Nm
M16	140 - 150 Nm
M24	350 - 400 Nm

8. Spare parts

The only parts that are available as spares are detailed in the table below.

Available spares

Strainer screen (state material, size of perforation or mesh and model /size of strainer)	3
Cap gasket (packet of 3)	8

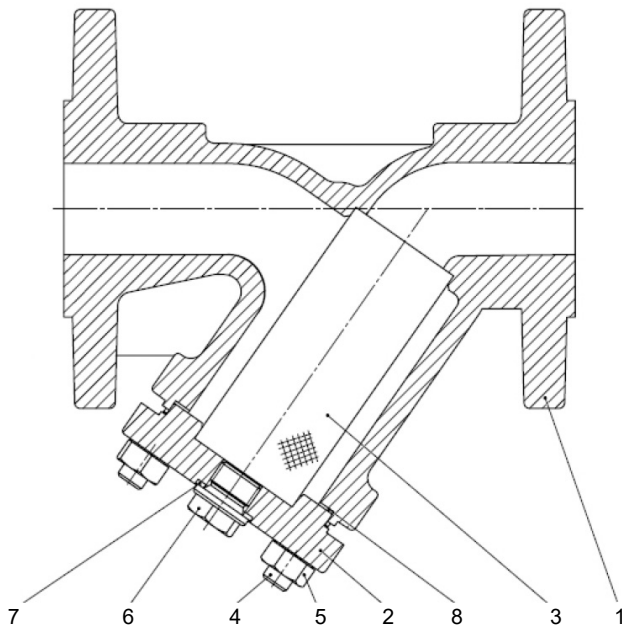

How to order spares

Always order spares by using the description given in the column headed 'Available spares' and state the size and type of strainer and perforations or mesh required.

Example: 1 - Stainless steel strainer screen having 1.0 mm perforations for a Spirax Sarco PN16 DN50 Fig 12 strainer.

REPAIRS

Please contact our nearest Branch Office or Agent, or directly:

Spirax Sarco S.r.l. - Servizio Assistenza Via per Cinisello, 18 - 20834 Nova Milanese (MB) - Italy Tel.: (+39) 0362 4917 257 - (+39) 0362 4917 211 - Fax: (+39) 0362 4917 315 E-mail: support@it.spiraxsarco.com

LOSS OF GUARANTEE

Total or partial disregard of above instructions involves loss of any right to guarantee.

Spirax-Sarco S.r.l. - Via per Cinisello, 18 - 20834 Nova Milanese (MB) - Tel.: 0362 49 17.1 - Fax: 0362 49 17 307
