

# BT-2GM Two-Piece Screwed Ends Ball Valve

BT-2GM30 (3000PSI) : 1/4~1-1/2" Full Port ,2" Reduce Port  
 BT-2GM60 (6000PSI) : 1/4~1-1/2" Full Port ,2"Reduce Port

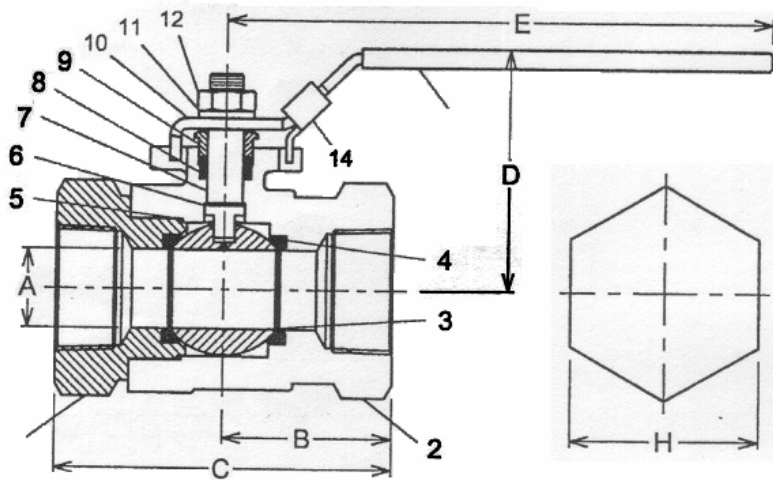
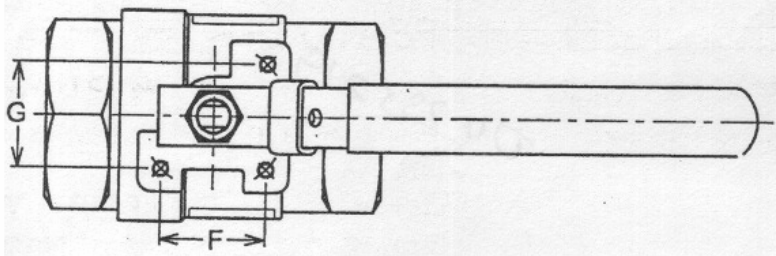

## FEATURES

1. INVESTMENT CASTING
2. FLOATING BALL
3. LOCKING LEVER HANDLE
4. ACTUATOR MOUNTING PAD
5. FIRE SAFE DESIGN
6. THREADS CONFORM TO ANSI B1.20.1 , BS21, DIN 259/2999

NO.	PART'S NAME	MATERIAL	
1	CAP	CF8M	WCB
2	BODY	CF8M	WCB
3	BALL	CF8M	CF8
4	BALL SEAT	DELRIN	
5	JOINT GASKET	PTFE	
6	THRUST WASHER	PTFE+15%GF	
7	STEM	AISI 316	
8	STEM PACKING	GRAPHITE	
9	GLAND NUT	AISI 304	
10	HANDLE	AISI 304	
11	SPRING WASHER	AISI 304	
12	STEM NUT	AISI 304	
13	HANDLE COVER	PLASTIC	
13	LOCKING DEVICE	AISI 304	

## DIMENSIONS

UNIT:MM

SIZE	1/4"	3/8"	1/2"	3/4"	1"	1-1/4"	1-1/2"	2"
A	6.3	9.6	12.7	19	25.4	31.8	38.1	38.1
B	38	38	50	54	57	60.5	67	79
C	76	76	101	108	115	121	134	158
D	56	56	56	69	89	125	114	114
E	126	126	126	158	207	207	257	257
F	25.5	25.5	25.5	30	35.5	35.5	49.5	49.5
G	25.5	25.5	25.5	30	35.5	35.5	49.5	49.5
H	30	31.8	31.8	31.8	46.1	57.2	70	76.2
	60							88.9
T	No.12-24UNC				1/4-20UNC	5/16-18UNC		

## TEST PRESSURE

SHELL TEST (WATER)	4500PSI(30)	9000PSI(60)
SEAT TEST (WATER)	3300PSI(30)	6600PSI(60)
SEAT TEST (AIR)	85PSI	

## PRESSURE-TEMPERATURE RATING

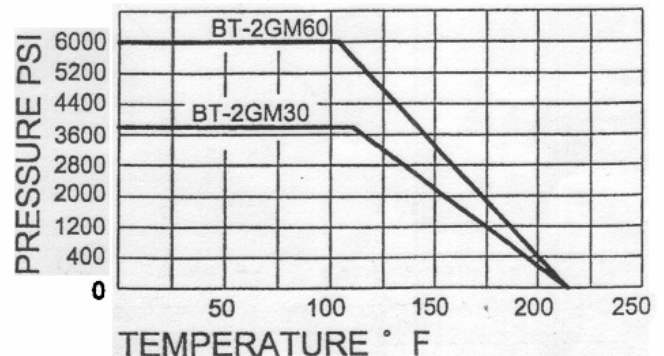

LYC TAIWAN