

# DB Series Duplex Basket Strainers

1/2' TO 4' PVC, CPVC, GFPP AND EASTAR®



## KEY FEATURES

- PVC, CPVC, GFPP and Eastar
- No System Shutdown for Basket Cleaning
- Ergonomic Hand-Removable Cover
- In-Line or Loop Connections
- Integral Flat Mounting Bases
- External Cover Threads
- Hand Removable Vents on Covers
- Hand Removable Drains on Bodies

## OPTIONS

- Stainless Steel, Monel®, Hastelloy®, and Titanium Strainer Baskets
- Pressure Differential Gauge and Switch
- Pneumatic or Electric Valve Automation
- Baskets Available with Perforated or Mesh Liners

## MATERIALS

- PVC Cell Class 12454 per ASTM D1784
- CPVC Cell Class 23447 per ASTM D1784
- GFPP Cell Class 85580 per ASTM D4101
- Eastar
- FPM and EPDM O-Ring Seals

## TECHNICAL INFORMATION

### BASKET OPTIONS

PERFORATION SIZES	MESH SIZES	BASKET MATERIAL
1/32"	20	SSTL, Hastelloy, Monel and Titanium
1/16"	40	
1/8"	60	
5/32"	80	
3/16"	100	
1/4"	200	
3/8"	325	
1/32"	N/A	PVC, CPVC and PP
1/16"		
1/8"		
3/16"		

### SELECTION CHART

SIZE	MATERIAL	END CONNECTION	SEALS	PRESSURE RATING
1/2" – 4" (DN15 – DN100)	PVC, CPVC and GFPP	Socket, Threaded or Flanged	FPM or EPDM	150 PSI @ 70°F Non-Shock
	Eastar*			100 PSI @ 70°F Non-Shock

\* End connections and assembly nuts are PVC.

# DB Series Duplex Basket Strainers

1/2" TO 4" PVC, CPVC, GFPP AND EASTAR®

## TECHNICAL INFORMATION, CONTINUED

### PARTS LIST

1. Single Stem Lateral
2. Double Stem Lateral
3. Inlet Flange
4. Cover
5. Strainer Body
6. Spool
7. Drain Plug and O-Ring
8. Vent Plug and O-Ring

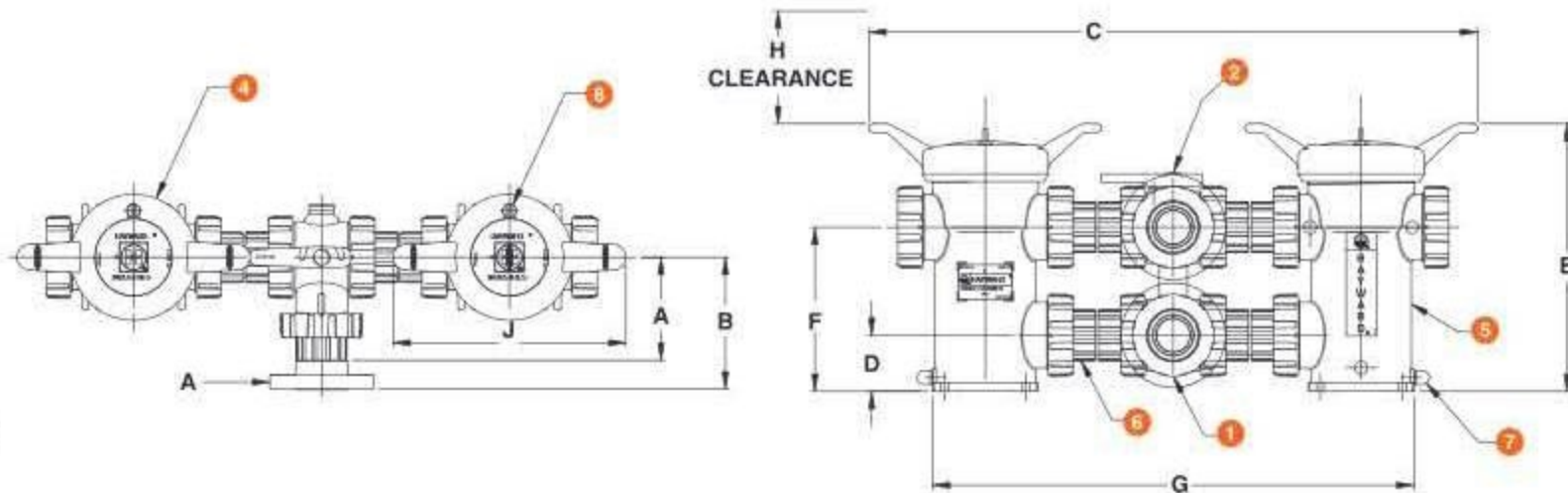

### DIMENSIONS – INCHES / MILLIMETERS

SIZE in / DN	A in / mm	B in / mm	C in / mm	D in / mm	E in / mm	F in / mm	G in / mm	H in / mm	J in / mm	WEIGHT lbs / kg	
										SOC / THD	FLANGED
1/2 / 15	4.14 / 105	5.21 / 132	27.20 / 691	2.25 / 57	11.70 / 297	6.75 / 171	20.50 / 521	5.00 / 127	11.00 / 279	20.00 / 9.07	21.00 / 9.53
3/4 / 20	4.14 / 105	5.33 / 135	27.20 / 691	2.25 / 57	11.70 / 297	6.75 / 171	20.50 / 521	5.00 / 127	11.00 / 279	20.00 / 9.07	21.00 / 9.53
1 / 25	4.14 / 105	5.64 / 143	27.20 / 691	2.25 / 57	11.70 / 297	6.75 / 171	20.50 / 521	5.00 / 127	11.00 / 279	20.00 / 9.07	21.00 / 9.53
1-1/4 / 32	6.00 / 152	7.44 / 189	35.30 / 897	3.25 / 83	15.50 / 394	9.50 / 241	28.00 / 711	10.80 / 274	13.50 / 343	39.50 / 17.92	42.00 / 19.05
1-1/2 / 40	6.00 / 152	7.60 / 193	35.30 / 897	3.25 / 83	15.50 / 394	9.50 / 241	28.00 / 711	10.80 / 274	13.50 / 343	39.50 / 17.92	42.00 / 19.05
2 / 50	6.00 / 152	7.77 / 197	35.30 / 897	3.25 / 83	15.50 / 394	9.50 / 241	28.00 / 711	10.80 / 274	13.50 / 343	39.50 / 17.92	42.00 / 19.05
2-1/2 / 63	7.60 / 193	9.85 / 250	44.40 / 1128	4.83 / 123	22.30 / 566	14.83 / 377	35.60 / 904	14.80 / 376	16.00 / 406	83.00 / 37.65	88.00 / 39.92
3 / 80	7.60 / 193	9.85 / 250	44.40 / 1128	4.83 / 123	22.30 / 566	14.83 / 377	35.60 / 904	14.80 / 376	16.00 / 406	83.00 / 37.65	88.50 / 40.14
4 / 100	9.33 / 237	11.76 / 299	47.50 / 1207	4.83 / 123	22.30 / 566	14.83 / 377	38.70 / 983	14.80 / 376	16.00 / 406	100.00 / 45.36	105.00 / 47.63

Dimensions are subject to change without notice – consult factory for installation information

### PRESSURE DROP CALCULATIONS

#### BASKET PERFORATION CORRECTION FACTORS

For 1/2" to 4" Strainers

Plastic		Stainless Steel	
1/32"	1.05	1/32"	.82
1/16"	1.00	1/16"	.74
1/8"	.58	1/8"	.58
3/16"	.46	5/32"	.37
		3/16"	.46
		1/4"	.58
		3/8"	.45
		20 Mesh	.79
		40 Mesh	1.01
		60 Mesh	1.20
		80 Mesh	1.16
		100 Mesh	1.20
		200 Mesh	1.09
		325 Mesh	1.22

#### PRESSURE LOSS CALCULATION FORMULA

$$\Delta P = \left[ \frac{Q}{C_v} \right]^2$$

The pressure drop across the strainer, for water or fluids with a similar viscosity, can be calculated using the formula at the right:

$\Delta P$  = Pressure Drop  
 $Q$  = Flow in GPM  
 $C_v$  = Flow Coefficient

### Cv VALUES

SIZE in / DN	Cv VALUES GPM	SIZE in / DN	Cv VALUES GPM
1/2 / 15	12.5	1-1/2 / 40	45
3/4 / 20	13	2 / 50	48
1 / 25	14	3 / 80	200
1-1/4 / 32	40	4 / 100	280

The above Cv Values were determined using a 1/16" perforated plastic basket in 1/2" through 4" strainers.

To calculate pressure drop through vessels using other than 1/16" perforated baskets, first calculate the pressure drop using the listed Cv, and then multiply the result by the correction factor in the Correction Factors chart to the left.

### OPERATING TEMPERATURE / PRESSURE

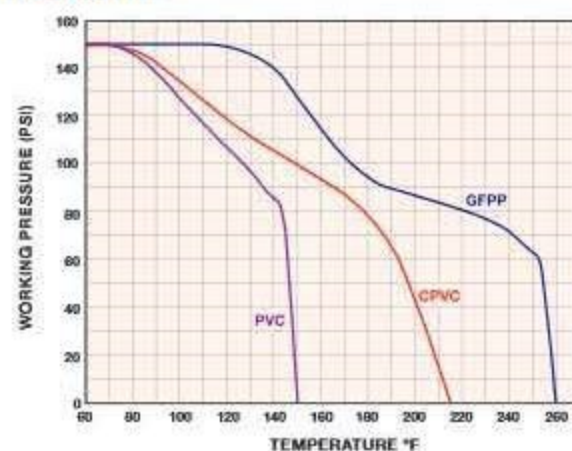

– Eastar is a registered trademark of Eastman.  
 – Hastelloy is a registered trademark of Haynes International Inc.  
 – Monel is a registered trademark of Special Metals Corporation.