

BOTH - WELL

HIGH PRESSURE FITTINGS

**FORGED
CARBON ALLOY
STAINLESS STEEL
THREADED SOCKETWELD**

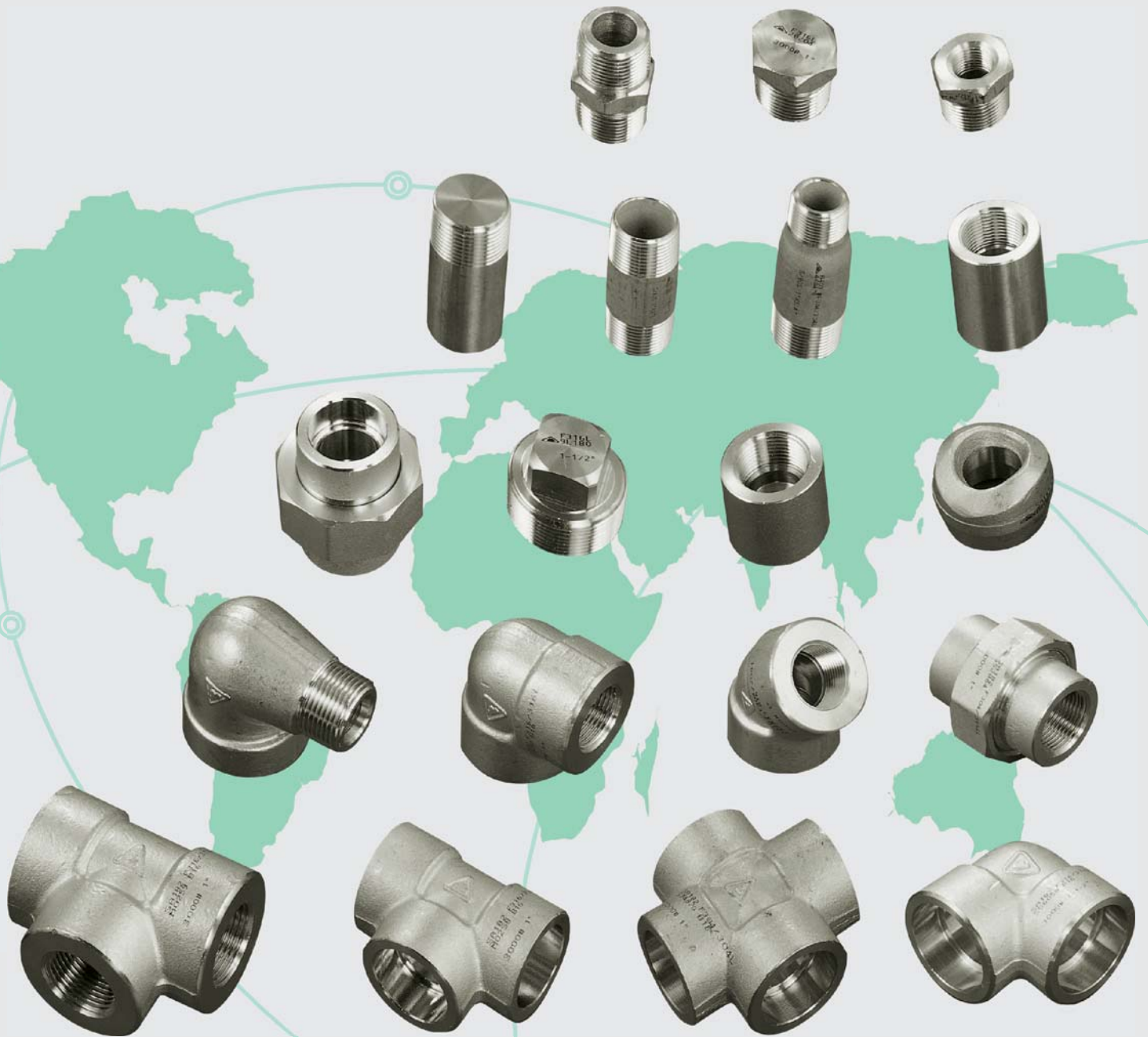

BOTH-WELL STEEL FITTINGS CO., LTD.

NO.303 Rensin Road, Renwu District, Kaohsiung City,
Taiwan, R.O.C. (81460)

TEL : 886-7-371-1536 ● 371-0497 ● 372-0260

FAX : 886-7-371-3864 ● 371-3882





INTRODUCTION

BOTH-WELL is equivalent to Win-Win, existing in between both consumers and manufacturer, both devoted employers and valued employees, a bilateral satisfaction.

Ever since its establishment in 1985, with the spirit of pursuing most advanced technology and striving for the ultimate quality-oriented products, the company is continuously utilizing the most up-to-date hi-tech facilities and most sophisticated manufacturing techniques, on the basis of skilled manpower and accumulated experiences, BOTH-WELL has been well-recognized among customers worldwide for the excellence of Quality and Services which has enabled us to win the unrivalled reputation in our industries.

QUALITY ASSURANCE

It is our indelible belief in Quality First.

BOTH-WELL's Quality Management System has been certified with ISO 9001:2008, PED, together with all major international-recognized certificates and being granted as an approval vendor for ARAMCO, also being listed on the Approval Supplier List of major domestic refineries, petro-chemical factories in Taiwan.

BOTH-WELL prides itself in having the best service performance in our industries which can only attribute it to the quality of people we employ and the amicable relationship and close partnership we have built-up with all our customers, and the company will continue its ultimate efforts to satisfy all its customers' demands by providing top quality products and high efficient services by anticipating the continued encouragement and supports from all its customers in the years ahead.

PRODUCTION RANGE AND SPECIFICATION :

TYPE : A. ELBOW, TEE, COUPLING, HALF COUPLING, CAP, PLUG, BUSHING, UNION, OUTLET, SWAGE NIPPLE, BULL PLUG, REDUCER INSERT AND HEX. NIPPLE, STREET ELBOWS, BOSS,...ETC.
 B. SOCKET-WELD, THREADED (NPT, PT, and BSP (ISO7-1, ISO228-1)), BUTT-WELDING.

SIZE : NPS 1/8" ~ 4".
 DN 6~100

RATING : PRESSURE : THREADED END - 2000 / 3000 / 6000 LBS.
 SOCKET-WELD END - 3000 / 6000 / 9000 LBS.
 BUTT WELD END - SCH40 / SCH80 / SCH160 / XXS.

SPECIFICATIONS : A. DIM. SPEC. : ASME B16.11-2011(REVISION of ASME B16.11-2009)
 MSS SP - 79, 83, 95, 97 and BS3799.
 B. MATERIAL SPEC : ASTM A105, A350 LF2, A106, A312, A234, A403.
 ASTM A182 (F304, F304L, F316, F316L, F304H, F316H, F317L, F321, F5, F9, F11, F22, F44, F51/60, F53, F91).
 C. SIZE of RAW MATERIAL : DIA. 19 ~120mm ROUND BAR.

MARKING : A. CARBON and ALLOY STEEL : MARKED BY STAMPING or LASER MARKING.
 B. STAINLESS STEEL : MARKED BY JET PRINTING or STAMPING or LASER MARKING.
 C. 3/8" UNDER : BRAND ONLY.
 D. 1/2" to 4" : MARKED WITH BRAND, MATERIAL, HEAT CODE, B16 (FOR ASME B16.11 PRODUCT), RATING and SIZE.

FINISHING : CARBON STEEL - GALVANIZED, PHOSPHATE, or ANTI-RUST OIL COATING.
 LOW ALLOY STEEL - PHOSPHATE, or ANTI-RUST OIL COATING.
 STAINLESS STEEL - PICKLED.

PACKING : CARTON / WOODEN CASE.
 PLYWOODEN CASE



PRODUCTION PROCESS CHART

(1) FORGING



(2) MACHINING - SOCKET WELD

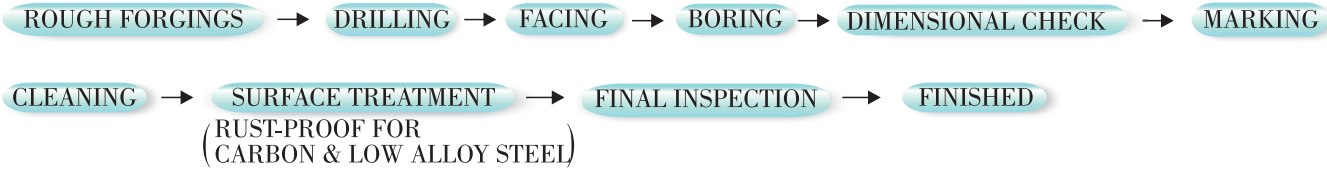

(3) MACHINING - THREADED

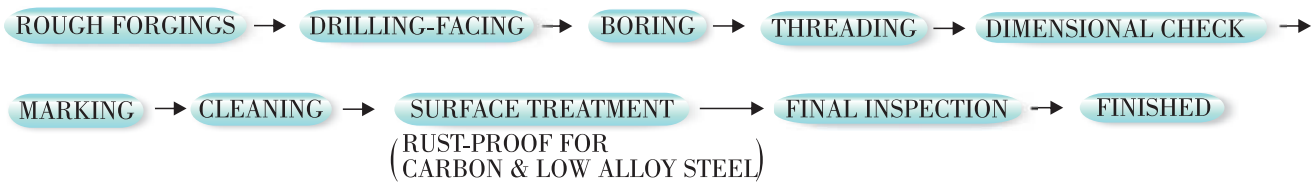

(4) DELIVERY



簡要作業流程圖

一、鍛造



二、套焊加工

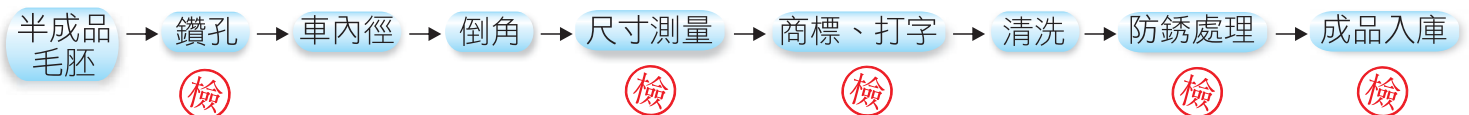

三、牙口加工

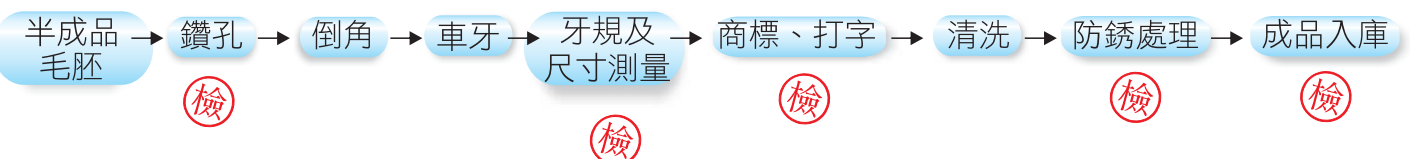

四、交貨處理

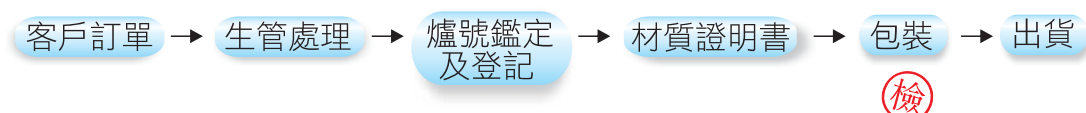



THE EQUIPMENT



沖床及感應加熱設備鍛造設備操作現場 ▲
HIGH SPEED PNEUMATIC PRESS EQUIPPED WITH INDUCTION HEATER

▼熱處理設備
FURNACE FOR HEAT TREATMENT

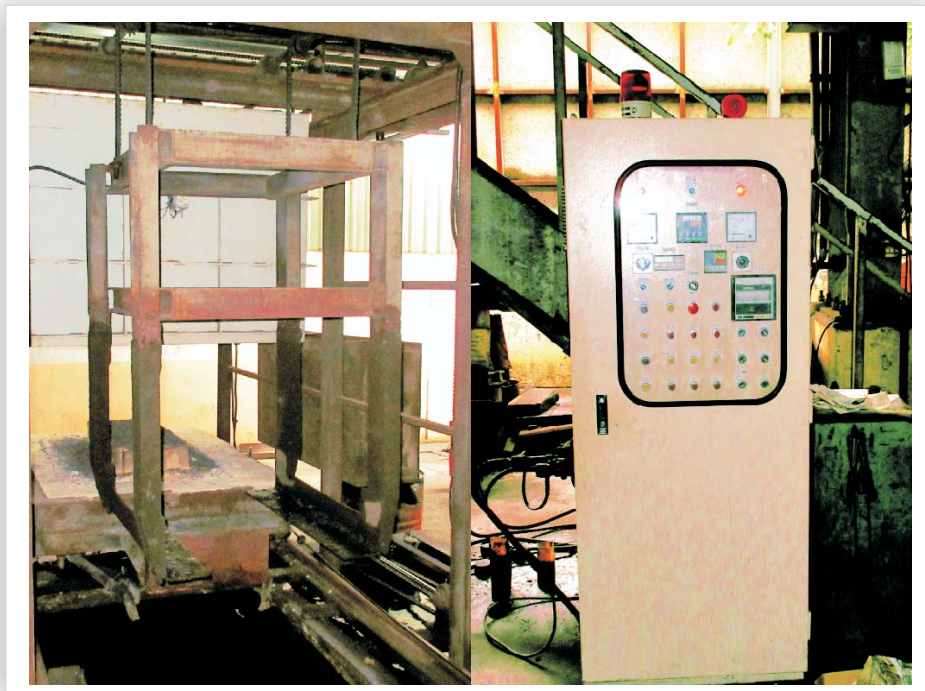



THE EQUIPMENT

CNC車床加工操作現場▶
CNC MACHINES



◀ 鑽孔機設備操作現場
▼ SPECIALIZED DRILLING MACHINES





THE ENVIRONMENT



◀ 量具校驗區
Gage and Calibration area



倉儲區 ▶
Warehouse Area



◀ 毛胚區
Rough Forgings Area



ISO17025 LABORATORY

TESTING LABORATORY



- ◀ 洛氏硬度試驗
ROCKWELL HARDNESS TESTING
ASTM E18
JIS Z2245
(40 to 100)HRBW
(20 to 65)HRC



- ◀ 勃氏硬度試驗
BRINELL HARDNESS TESTING
ASTM E10
JIS Z2243
(100 to 440) HBW 10/3000



- ◀ 拉伸試驗
TENSILE TESTING
ASTM E8/E8M
JIS Z2241
(1000 to 30000) KGF



- ◀ 水壓試驗
HYDROSTATIC TESTING
ASME B31.1
ASME B31.3
BS 3799
JIS B2316
Max to 30000 psi



- ◀ 晶界腐蝕試驗
INTERGRANULAR CORROSION TESTING
ASTM A262 Practice E
JIS G0575



INSPECTION APPARATUS



▲ 分光分析儀
OPTICAL EMISSION SPECTROMETER



▲ 手持式分光分析儀
POSITIVE MATERIAL
IDENTIFICATION (PMI)



▲ 精密光學投影機
PRECISION PROJECTOR



▲ 磁力檢測設備
MAGNETIC PARTICLE
TESTING (MT) EQPT .



▲ 液滲檢測工具
LIQUID PENETRATE
TESTING (PT) EQPT .

金相設備 METALLURGICAL EQUIPMENT



切割
CUTTING



鑲埋
MOUNTING PRESS



研磨和拋光
GRINDING & POLISHING



金相顯微鏡
METALLOGRAPHIC MICROSCOPE



BOTH-WELL



HEADQUARTER

MACHINING SHOPS



FORGING SHOP





CERTIFICATION

We Have Obtained The Following Internationally Recognized Approvals With Certificates:



An ISO 9001 Registered Manufacturer

Certificate No.01 100 126923



Lloyd's Register of Shipping

Certificate No. MD00/0208/0007/3



AMERICAN BUREAU OF SHIPPING TAIWAN CO., LTD

Certificate No. KS2368613-X



中國驗船中心
China Corporation Register of Shipping

Certificate No.472-15-057



Quality-Assurance System for Manufacturer of Materials
acc.to Directive 97/23/EC

Certificate No. 01 202 TWN/Q-12 0247



BUREAU VERITAS OF MARINE DIVISION

Certificate No. SMS.W.II/51004/D.0



TAIWAN ACCREDITATION FOUNDATION ISO/IEC 17025:2005

Certificate No. L3189-160120



PRODUCT LIST

FORGED HIGH PRESSURE PIPE FITTINGS SOCKET WELD 3000-6000-9000 Lbs

ELBOW
90°



HALF
COUPLING



ELBOW
45°



CAP



TEE



BOSS



CROSS



OUTLET



45° BRANCH
OUTLET



UNION



INSERT













COUPLING



SWAGE
NIPPLE



FORGED HIGH PRESSURE PIPE FITTINGS THREADED 2000-3000-6000 Lbs

ELBOW 90°		COUPLING		SQUARE HEAD PLUG	
ELBOW 45°		HALF COUPLING		ROUND HEAD PLUG	
TEE		REDUCING COUPLING		BULL PLUG	
CROSS		CAP		BOSS	
STREET ELBOW		45° BRANCH OUTLET		OUTLET	
UNION		HEX HEAD BUSHING		HEX NIPPLE	
		HEX HEAD PLUG		SWAGE NIPPLE	

FORGED HIGH PRESSURE PIPE FITTINGS BUTT WELD SCH40-SCH80-SCH160-XXS

WELDING
OUTLET



SWAGE
NIPPLE



45° BRANCH
OUTLET



FORGED HIGH PRESSURE PIPE FITTINGS SPECIAL PRODUCTS

45° LATERAL
TEE



NIPPLOLET





90° ELBOW

ASME B16.11-2011(Revision of ASME B16.11-2009)

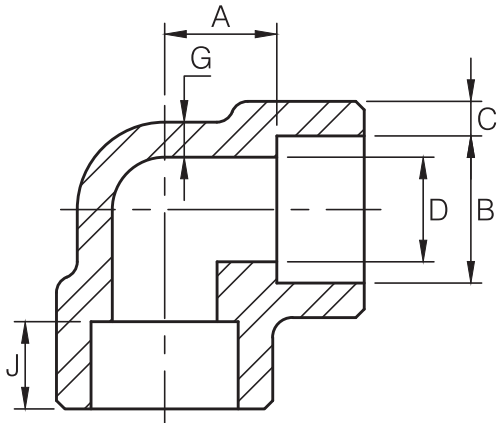

Dimensions are in millimeters.

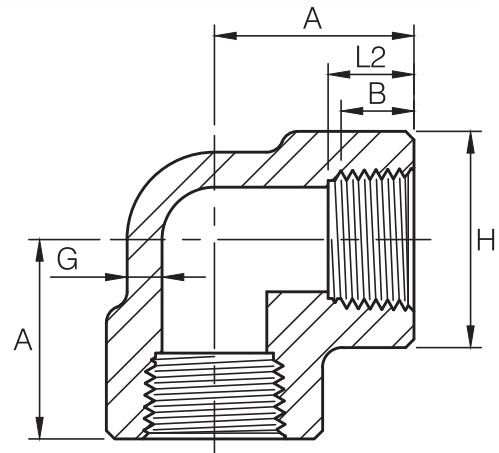

Dimensions are in millimeters.

Socket Welding								
DN	Nom. Pipe Size	B ⁽²⁾	C ⁽¹⁾		D ⁽²⁾	A ⁽²⁾	G (Min)	J (Min)
			(Avg)	(Min)				

3000Lb								
6	1/8	10.8	3.18	3.18	6.9	11.0	2.41	9.5
8	1/4	14.2	3.78	3.30	9.3	11.0	3.02	9.5
10	3/8	17.6	4.01	3.50	12.6	13.5	3.20	9.5
15	1/2	21.8	4.67	4.09	15.8	15.5	3.73	9.5
20	3/4	27.2	4.90	4.27	21.0	19.0	3.91	12.5
25	1	33.9	5.69	4.98	26.7	22.5	4.55	12.5
32	1-1/4	42.7	6.07	5.28	35.1	27.0	4.85	12.5
40	1-1/2	48.8	6.35	5.54	40.9	32.0	5.08	12.5
50	2	61.2	6.93	6.04	52.5	38.0	5.54	16.0
65	2-1/2	73.9	8.76	7.67	62.7	41.0	7.01	16.0
80	3	89.8	9.52	8.30	78.0	57.0	7.62	16.0
100	4	115.2	10.69	9.35	102.3	66.5	8.56	19.0

6000Lb								
6	1/8	10.8	3.96	3.43	4.0	11.0	3.15	9.5
8	1/4	14.2	4.60	4.01	6.4	13.5	3.68	9.5
10	3/8	17.6	5.03	4.37	9.2	15.5	4.01	9.5
15	1/2	21.8	5.97	5.18	11.8	19.0	4.78	9.5
20	3/4	27.2	6.96	6.04	15.6	22.5	5.56	12.5
25	1	33.9	7.92	6.93	20.7	27.0	6.35	12.5
32	1-1/4	42.7	7.92	6.93	29.5	32.0	6.35	12.5
40	1-1/2	48.8	8.92	7.80	34.0	38.0	7.14	12.5
50	2	61.2	10.92	9.50	42.9	41.0	8.74	16.0

9000Lb								
15	1/2	21.8	9.35	8.18	6.4	25.5	7.47	9.5
20	3/4	27.2	9.78	8.56	11.1	28.5	7.82	12.5
25	1	33.9	11.38	9.96	15.2	32.0	9.09	12.5
32	1-1/4	42.7	12.14	10.62	22.8	35.0	9.70	12.5
40	1-1/2	48.8	12.70	11.12	28.0	38.0	10.15	12.5
50	2	61.2	13.84	12.12	38.2	54.0	11.07	16.0

Threaded						
DN	Nom. Pipe Size	Length of Thread. (Min)		A	G (Min)	H
		B ^(*)	L2 ^(*)			

2000Lb						
6	1/8	6.4	6.7	21	3.18	22
8	1/4	8.1	10.2	21	3.18	22
10	3/8	9.1	10.4	25	3.18	25
15	1/2	10.9	13.6	28	3.18	33
20	3/4	12.7	13.9	33	3.18	38
25	1	14.7	17.3	38	3.68	46
32	1-1/4	17.0	18.0	44	3.89	56
40	1-1/2	17.8	18.4	51	4.01	62
50	2	19.0	19.2	60	4.27	75
65	2-1/2	23.6	28.9	76	5.61	92
80	3	25.9	30.5	86	5.99	109
100	4	27.7	33.0	106	6.55	146

3000Lb						
6	1/8	6.4	6.7	21	3.18	22
8	1/4	8.1	10.2	25	3.30	25
10	3/8	9.1	10.4	28	3.51	33
15	1/2	10.9	13.6	33	4.09	38
20	3/4	12.7	13.9	38	4.32	46
25	1	14.7	17.3	44	4.98	56
32	1-1/4	17.0	18.0	51	5.28	62
40	1-1/2	17.8	18.4	60	5.56	75
50	2	19.0	19.2	64	7.14	84
65	2-1/2	23.6	28.9	83	7.65	102
80	3	25.9	30.5	95	8.84	121
100	4	27.7	33.0	114	11.18	152

6000Lb						
6	1/8	6.4	6.7	25	6.35	25
8	1/4	8.1	10.2	28	6.60	33
10	3/8	9.1	10.4	33	6.98	38
15	1/2	10.9	13.6	38	8.15	46
20	3/4	12.7	13.9	44	8.53	56
25	1	14.7	17.3	51	9.93	62
32	1-1/4	17.0	18.0	60	10.59	75
40	1-1/2	17.8	18.4	64	11.07	84
50	2	19.0	19.2	83	12.09	102
65	2-1/2	23.6	28.9	95	15.29	121
80	3	25.9	30.5	106	16.64	146
100	4	27.7	33.0	114	18.67	152

(1) Average of socket Wall Thickness around periphery shall be no less than listed values. The minimum values are permitted in localized areas.

(2) Tolerance see page 20.

(*) Dimension B is minimum length of perfect thread. The length of useful thread (B plus threads with fully formed roots and flat crests) shall not be less than L2 (effective length of external thread) required by American National Standard for pipe threads (ANSI / ASME B1.20.1).



45° ELBOW

ASME B16.11-2011(Revision of ASME B16.11-2009)

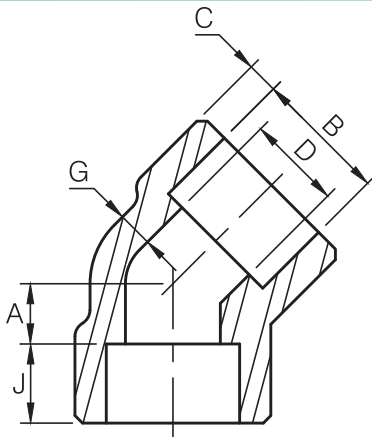

Dimensions are in millimeters.

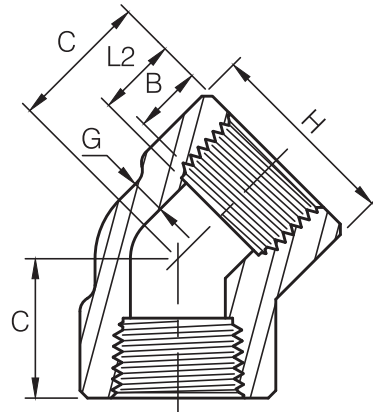

Dimensions are in millimeters.

Socket Welding								
DN	Nom. Pipe Size	B ⁽²⁾	C ⁽¹⁾		D ⁽²⁾	A ⁽²⁾	G (Min)	J (Min)
			(Avg)	(Min)				

3000Lb

6	1/8	10.8	3.18	3.18	6.9	8.0	2.41	9.5
8	1/4	14.2	3.78	3.30	9.3	8.0	3.02	9.5
10	3/8	17.6	4.01	3.50	12.6	8.0	3.20	9.5
15	1/2	21.8	4.67	4.09	15.8	11.0	3.73	9.5
20	3/4	27.2	4.90	4.27	21.0	13.0	3.91	12.5
25	1	33.9	5.69	4.98	26.7	14.0	4.55	12.5
32	1-1/4	42.7	6.07	5.28	35.1	17.5	4.85	12.5
40	1-1/2	48.8	6.35	5.54	40.9	20.5	5.08	12.5
50	2	61.2	6.93	6.04	52.5	25.5	5.54	16.0
65	2-1/2	73.9	8.76	7.67	62.7	28.5	7.01	16.0
80	3	89.8	9.52	8.30	78.0	32.0	7.62	16.0
100	4	115.2	10.69	9.35	102.3	41.0	8.56	19.0

6000Lb

6	1/8	10.8	3.96	3.43	4.0	8.0	3.15	9.5
8	1/4	14.2	4.60	4.01	6.4	8.0	3.68	9.5
10	3/8	17.6	5.03	4.37	9.2	11.0	4.01	9.5
15	1/2	21.8	5.97	5.18	11.8	12.5	4.78	9.5
20	3/4	27.2	6.96	6.04	15.6	14.0	5.56	12.5
25	1	33.9	7.92	6.93	20.7	17.5	6.35	12.5
32	1-1/4	42.7	7.92	6.93	29.5	20.5	6.35	12.5
40	1-1/2	48.8	8.92	7.80	34.0	25.5	7.14	12.5
50	2	61.2	10.92	9.50	42.9	28.5	8.74	16.0

9000Lb

15	1/2	21.8	9.35	8.18	6.4	15.5	7.47	9.5
20	3/4	27.2	9.78	8.56	11.1	19.0	7.82	12.5
25	1	33.9	11.38	9.96	15.2	20.5	9.09	12.5
32	1-1/4	42.7	12.14	10.62	22.8	22.5	9.70	12.5
40	1-1/2	48.8	12.70	11.12	28.0	25.5	10.15	12.5
50	2	61.2	13.84	12.12	38.2	28.5	11.07	16.0

(1) Average of socket Wall Thickness around periphery shall be no less than listed values. The minimum values are permitted in localized areas.

(2) Tolerance see page 20.

Threaded						
DN	Nom. Pipe Size	Length of Thread. (Min)		C	G (Min)	H
		B ^(*)	L2 ^(*)			

2000Lb

6	1/8	6.4	6.7	17	3.18	22
8	1/4	8.1	10.2	17	3.18	22
10	3/8	9.1	10.4	19	3.18	25
15	1/2	10.9	13.6	22	3.18	33
20	3/4	12.7	13.9	25	3.18	38
25	1	14.7	17.3	28	3.68	46
32	1-1/4	17.0	18.0	33	3.89	56
40	1-1/2	17.8	18.4	35	4.01	62
50	2	19.0	19.2	43	4.27	75
65	2-1/2	23.6	28.9	52	5.61	92
80	3	25.9	30.5	64	5.99	109
100	4	27.7	33.0	79	6.55	146

3000Lb

6	1/8	6.4	6.7	17	3.18	22
8	1/4	8.1	10.2	19	3.30	25
10	3/8	9.1	10.4	22	3.51	33
15	1/2	10.9	13.6	25	4.09	38
20	3/4	12.7	13.9	28	4.32	46
25	1	14.7	17.3	33	4.98	56
32	1-1/4	17.0	18.0	35	5.28	62
40	1-1/2	17.8	18.4	43	5.56	75
50	2	19.0	19.2	44	7.14	84
65	2-1/2	23.6	28.9	52	7.65	102
80	3	25.9	30.5	64	8.84	121
100	4	27.7	33.0	79	11.18	152

6000Lb

6	1/8	6.4	6.7	19	6.35	25
8	1/4	8.1	10.2	22	6.60	33
10	3/8	9.1	10.4	25	6.98	38
15	1/2	10.9	13.6	28	8.15	46
20	3/4	12.7	13.9	33	8.53	56
25	1	14.7	17.3	35	9.93	62
32	1-1/4	17.0	18.0	43	10.59	75
40	1-1/2	17.8	18.4	44	11.07	84
50	2	19.0	19.2	52	12.09	102
65	2-1/2	23.6	28.9	64	15.29	121
80	3	25.9	30.5	79	16.64	146
100	4	27.7	33.0	79	18.67	152

(*) Dimension B is minimum length of perfect thread. The length of useful thread (B plus threads with fully formed roots and flat crests) shall not be less than L2 (effective length of external thread) required by American National Standard for pipe threads (ANSI / ASME B1.20.1).



TEE

ASME B16.11-2011 (Revision of ASME B16.11-2009)

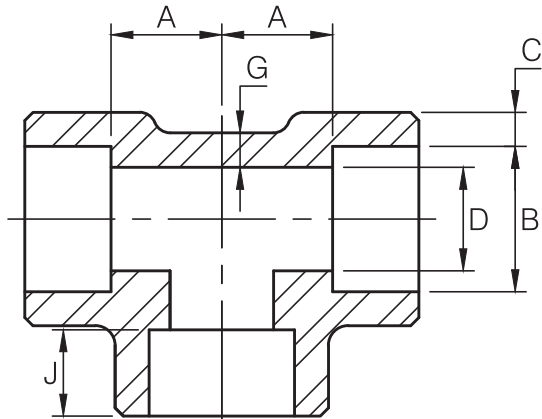

Dimensions are in millimeters.

Socket Welding								
DN	Nom. Pipe Size	B ⁽²⁾	C ⁽¹⁾		D ⁽²⁾	A ⁽²⁾	G (Min)	J (Min)
			(Avg)	(Min)				

3000Lb

6	1/8	10.8	3.18	3.18	6.9	11.0	2.41	9.5
8	1/4	14.2	3.78	3.30	9.3	11.0	3.02	9.5
10	3/8	17.6	4.01	3.50	12.6	13.5	3.20	9.5
15	1/2	21.8	4.67	4.09	15.8	15.5	3.73	9.5
20	3/4	27.2	4.90	4.27	21.0	19.0	3.91	12.5
25	1	33.9	5.69	4.98	26.7	22.5	4.55	12.5
32	1-1/4	42.7	6.07	5.28	35.1	27.0	4.85	12.5
40	1-1/2	48.8	6.35	5.54	40.9	32.0	5.08	12.5
50	2	61.2	6.93	6.04	52.5	38.0	5.54	16.0
65	2-1/2	73.9	8.76	7.67	62.7	41.0	7.01	16.0
80	3	89.8	9.52	8.30	78.0	57.0	7.62	16.0
100	4	115.2	10.69	9.35	102.3	66.5	8.56	19.0

6000Lb

6	1/8	10.8	3.96	3.43	4.0	11.0	3.15	9.5
8	1/4	14.2	4.60	4.01	6.4	13.5	3.68	9.5
10	3/8	17.6	5.03	4.37	9.2	15.5	4.01	9.5
15	1/2	21.8	5.97	5.18	11.8	19.0	4.78	9.5
20	3/4	27.2	6.96	6.04	15.6	22.5	5.56	12.5
25	1	33.9	7.92	6.93	20.7	27.0	6.35	12.5
32	1-1/4	42.7	7.92	6.93	29.5	32.0	6.35	12.5
40	1-1/2	48.8	8.92	7.80	34.0	38.0	7.14	12.5
50	2	61.2	10.92	9.50	42.9	41.0	8.74	16.0

9000Lb

15	1/2	21.8	9.35	8.18	6.4	25.5	7.47	9.5
20	3/4	27.2	9.78	8.56	11.1	28.5	7.82	12.5
25	1	33.9	11.38	9.96	15.2	32.0	9.09	12.5
32	1-1/4	42.7	12.14	10.62	22.8	35.0	9.70	12.5
40	1-1/2	48.8	12.70	11.12	28.0	38.0	10.15	12.5
50	2	61.2	13.84	12.12	38.2	54.0	11.07	16.0

(1) Average of socket Wall Thickness around periphery shall be no less than listed values. The minimum values are permitted in localized areas.

(2) Tolerance see page 20.

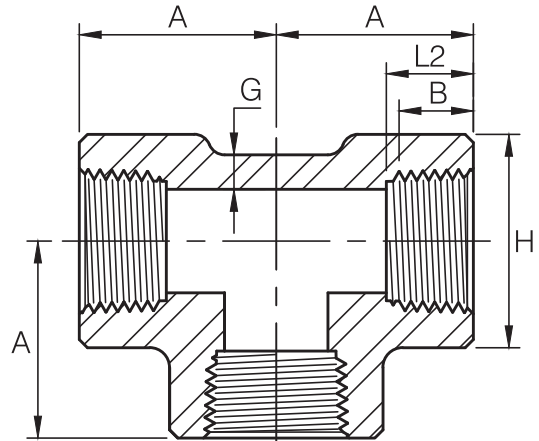

Dimensions are in millimeters.

Threaded						
DN	Nom. Pipe Size	Length of Thread. (Min)		A	G (Min)	H
		B ^(*)	L2 ^(*)			

2000Lb

6	1/8	6.4	6.7	21	3.18	22
8	1/4	8.1	10.2	21	3.18	22
10	3/8	9.1	10.4	25	3.18	25
15	1/2	10.9	13.6	28	3.18	33
20	3/4	12.7	13.9	33	3.18	38
25	1	14.7	17.3	38	3.68	46
32	1-1/4	17.0	18.0	44	3.89	56
40	1-1/2	17.8	18.4	51	4.01	62
50	2	19.0	19.2	60	4.27	75
65	2-1/2	23.6	28.9	76	5.61	92
80	3	25.9	30.5	86	5.99	109
100	4	27.7	33.0	106	6.55	146

3000Lb

6	1/8	6.4	6.7	21	3.18	22
8	1/4	8.1	10.2	25	3.30	25
10	3/8	9.1	10.4	28	3.51	33
15	1/2	10.9	13.6	33	4.09	38
20	3/4	12.7	13.9	38	4.32	46
25	1	14.7	17.3	44	4.98	56
32	1-1/4	17.0	18.0	51	5.28	62
40	1-1/2	17.8	18.4	60	5.56	75
50	2	19.0	19.2	64	7.14	84
65	2-1/2	23.6	28.9	83	7.65	102
80	3	25.9	30.5	95	8.84	121
100	4	27.7	33.0	114	11.18	152

6000Lb

6	1/8	6.4	6.7	25	6.35	25
8	1/4	8.1	10.2	28	6.60	33
10	3/8	9.1	10.4	33	6.98	38
15	1/2	10.9	13.6	38	8.15	46
20	3/4	12.7	13.9	44	8.53	56
25	1	14.7	17.3	51	9.93	62
32	1-1/4	17.0	18.0	60	10.59	75
40	1-1/2	17.8	18.4	64	11.07	84
50	2	19.0	19.2	83	12.09	102
65	2-1/2	23.6	28.9	95	15.29	121
80	3	25.9	30.5	106	16.64	146
100	4	27.7	33.0	114	18.67	152

(*) Dimension B is minimum length of perfect thread. The length of useful thread (B plus threads with fully formed roots and flat crests) shall not be less than L2 (effective length of external thread) required by American National Standard for pipe threads (ANSI / ASME B1.20.1).

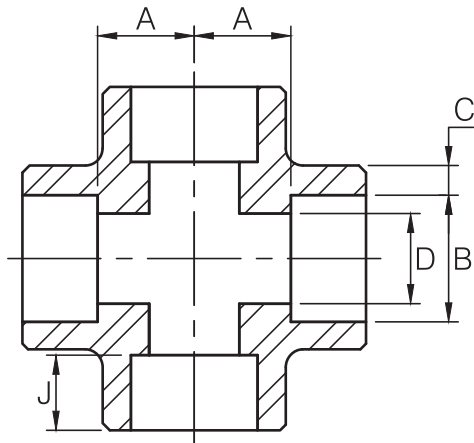

Dimensions are in millimeters.

Socket Welding							
DN	Nom. Pipe Size	B ⁽²⁾	C ⁽¹⁾		D ⁽²⁾	A ⁽²⁾	J (Min)
			(Avg)	(Min)			

3000Lb

6	1/8	10.8	3.18	3.18	6.9	11.0	9.5
8	1/4	14.2	3.78	3.30	9.3	11.0	9.5
10	3/8	17.6	4.01	3.50	12.6	13.5	9.5
15	1/2	21.8	4.67	4.09	15.8	15.5	9.5
20	3/4	27.2	4.90	4.27	21.0	19.0	12.5
25	1	33.9	5.69	4.98	26.7	22.5	12.5
32	1-1/4	42.7	6.07	5.28	35.1	27.0	12.5
40	1-1/2	48.8	6.35	5.54	40.9	32.0	12.5
50	2	61.2	6.93	6.04	52.5	38.0	16.0
65	2-1/2	73.9	8.76	7.67	62.7	41.0	16.0
80	3	89.8	9.52	8.30	78.0	57.0	16.0
100	4	115.2	10.69	9.35	102.3	66.5	19.0

6000Lb

6	1/8	10.8	3.96	3.43	4.0	11.0	9.5
8	1/4	14.2	4.60	4.01	6.4	13.5	9.5
10	3/8	17.6	5.03	4.37	9.2	15.5	9.5
15	1/2	21.8	5.97	5.18	11.8	19.0	9.5
20	3/4	27.2	6.96	6.04	15.6	22.5	12.5
25	1	33.9	7.92	6.93	20.7	27.0	12.5
32	1-1/4	42.7	7.92	6.93	29.5	32.0	12.5
40	1-1/2	48.8	8.92	7.80	34.0	38.0	12.5
50	2	61.2	10.92	9.50	42.9	41.0	16.0

9000Lb

15	1/2	21.8	9.35	8.18	6.4	25.5	9.5
20	3/4	27.2	9.78	8.56	11.1	28.5	12.5
25	1	33.9	11.38	9.96	15.2	32.0	12.5
32	1-1/4	42.7	12.14	10.62	22.8	35.0	12.5
40	1-1/2	48.8	12.70	11.12	28.0	38.0	12.5
50	2	61.2	13.84	12.12	38.2	54.0	16.0

(1) Average of socket Wall Thickness around periphery shall be no less than listed values. The minimum values are permitted in localized areas.

(2) Tolerance see page 20.

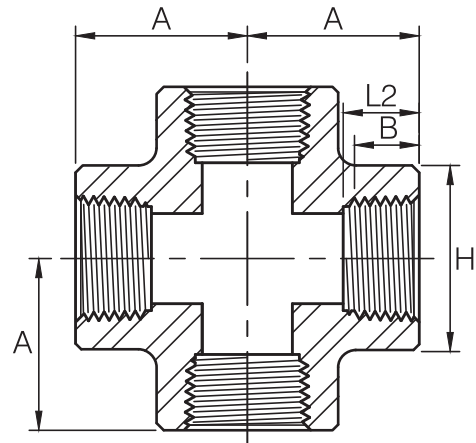

Dimensions are in millimeters.

Threaded					
DN	Nom. Pipe Size	Length of Thread. (Min)		A	H
		B ^(*)	L2 ^(*)		

2000Lb

6	1/8	6.4	6.7	21	22
8	1/4	8.1	10.2	21	22
10	3/8	9.1	10.4	25	25
15	1/2	10.9	13.6	28	33
20	3/4	12.7	13.9	33	38
25	1	14.7	17.3	38	46
32	1-1/4	17.0	18.0	44	56
40	1-1/2	17.8	18.4	51	62
50	2	19.0	19.2	60	75
65	2-1/2	23.6	28.9	76	92
80	3	25.9	30.5	86	109
100	4	27.7	33.0	106	146

3000Lb

6	1/8	6.4	6.7	21	22
8	1/4	8.1	10.2	25	25
10	3/8	9.1	10.4	28	33
15	1/2	10.9	13.6	33	38
20	3/4	12.7	13.9	38	46
25	1	14.7	17.3	44	56
32	1-1/4	17.0	18.0	51	62
40	1-1/2	17.8	18.4	60	75
50	2	19.0	19.2	64	84
65	2-1/2	23.6	28.9	83	102
80	3	25.9	30.5	95	121
100	4	27.7	33.0	114	152

6000Lb

6	1/8	6.4	6.7	25	25
8	1/4	8.1	10.2	28	33
10	3/8	9.1	10.4	33	38
15	1/2	10.9	13.6	38	46
20	3/4	12.7	13.9	44	56
25	1	14.7	17.3	51	62
32	1-1/4	17.0	18.0	60	75
40	1-1/2	17.8	18.4	64	84
50	2	19.0	19.2	83	102
65	2-1/2	23.6	28.9	95	121
80	3	25.9	30.5	106	146
100	4	27.7	33.0	114	152

(*) Dimension B is minimum length of perfect thread. The length of useful thread (B plus threads with fully formed roots and flat crests) shall not be less than L2 (effective length of external thread) required by American National Standard for pipe threads (ANSI / ASME B1.20.1).



FULL COUPLING

ASME B16.11-2011 (Revision of ASME B16.11-2009)

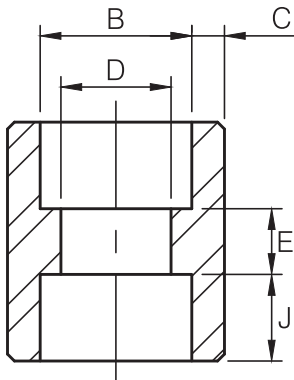

Dimensions are in millimeters.

Socket Welding							
DN	Nom. Pipe Size	B ⁽²⁾	C ⁽¹⁾		D ⁽²⁾	E ⁽²⁾	J (Min)
			(Avg)	(Min)			

3000Lb

6	1/8	10.8	3.18	3.18	6.9	6.5	9.5
8	1/4	14.2	3.78	3.30	9.3	6.5	9.5
10	3/8	17.6	4.01	3.50	12.6	6.5	9.5
15	1/2	21.8	4.67	4.09	15.8	9.5	9.5
20	3/4	27.2	4.90	4.27	21.0	9.5	12.5
25	1	33.9	5.69	4.98	26.7	12.5	12.5
32	1-1/4	42.7	6.07	5.28	35.1	12.5	12.5
40	1-1/2	48.8	6.35	5.54	40.9	12.5	12.5
50	2	61.2	6.93	6.04	52.5	19.0	16.0
65	2-1/2	73.9	8.76	7.67	62.7	19.0	16.0
80	3	89.8	9.52	8.30	78.0	19.0	16.0
100	4	115.2	10.69	9.35	102.3	19.0	19.0

6000Lb

6	1/8	10.8	3.96	3.43	4.0	6.5	9.5
8	1/4	14.2	4.60	4.01	6.4	6.5	9.5
10	3/8	17.6	5.03	4.37	9.2	6.5	9.5
15	1/2	21.8	5.97	5.18	11.8	9.5	9.5
20	3/4	27.2	6.96	6.04	15.6	9.5	12.5
25	1	33.9	7.92	6.93	20.7	12.5	12.5
32	1-1/4	42.7	7.92	6.93	29.5	12.5	12.5
40	1-1/2	48.8	8.92	7.80	34.0	12.5	12.5
50	2	61.2	10.92	9.50	42.9	19.0	16.0

9000Lb

15	1/2	21.8	9.35	8.18	6.4	9.5	9.5
20	3/4	27.2	9.78	8.56	11.1	9.5	12.5
25	1	33.9	11.38	9.96	15.2	12.5	12.5
32	1-1/4	42.7	12.14	10.62	22.8	12.5	12.5
40	1-1/2	48.8	12.70	11.12	28.0	12.5	12.5
50	2	61.2	13.84	12.12	38.2	19.0	16.0

(1) Average of socket Wall Thickness around periphery shall be no less than listed values. The minimum values are permitted in localized areas.

(2) Tolerance see page 20.

(3) Reducer : "C, J, E" in accordance with large size.

"D" in accordance with small size.

The others in accordance with each size.

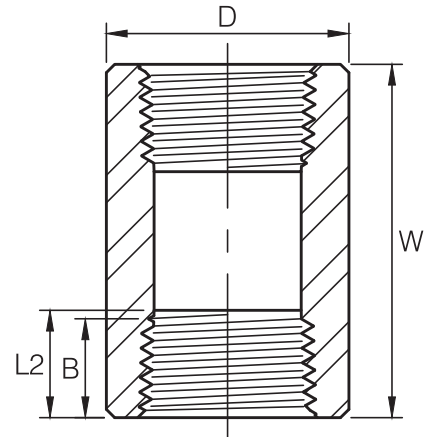

Dimensions are in millimeters.

Threaded					
DN	Nom. Pipe Size	Length of Thread. (Min)		W	D
		B ^(*)	L2 ^(*)		

3000Lb

6	1/8	6.4	6.7	32	16
8	1/4	8.1	10.2	35	19
10	3/8	9.1	10.4	38	22
15	1/2	10.9	13.6	48	28
20	3/4	12.7	13.9	51	35
25	1	14.7	17.3	60	44
32	1-1/4	17.0	18.0	67	57
40	1-1/2	17.8	18.4	79	64
50	2	19.0	19.2	86	76
65	2-1/2	23.6	28.9	92	92
80	3	25.9	30.5	108	108
100	4	27.7	33.0	121	140

6000Lb

6	1/8	6.4	6.7	32	22
8	1/4	8.1	10.2	35	25
10	3/8	9.1	10.4	38	32
15	1/2	10.9	13.6	48	38
20	3/4	12.7	13.9	51	44
25	1	14.7	17.3	60	57
32	1-1/4	17.0	18.0	67	64
40	1-1/2	17.8	18.4	79	76
50	2	19.0	19.2	86	92
65	2-1/2	23.6	28.9	92	108
80	3	25.9	30.5	108	127
100	4	27.7	33.0	121	159

(*) Dimension B is minimum length of perfect thread. The length of useful thread (B plus threads with fully formed roots and flat crests) shall not be less than L2 (effective length of external thread) required by American National Standard for pipe threads (ANSI / ASME B1.20.1).



HALF COUPLING

ASME B16.11-2011(Revision of ASME B16.11-2009)

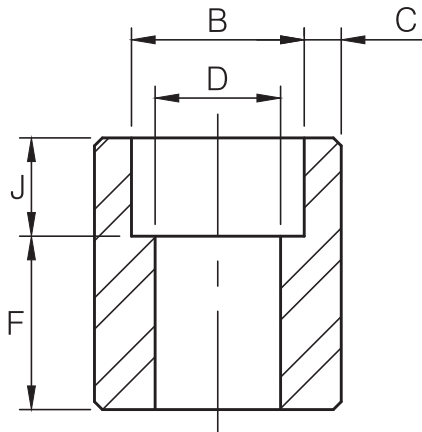

Dimensions are in millimeters.

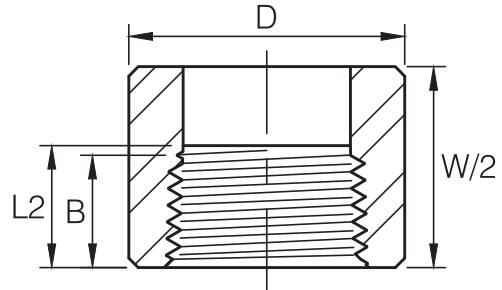

Dimensions are in millimeters.

Socket Welding							
DN	Nom. Pipe Size	B ⁽²⁾	C ⁽¹⁾		D ⁽²⁾	F ⁽²⁾	J (Min)
			(Avg)	(Min)			

3000Lb

6	1/8	10.8	3.18	3.18	6.9	16.0	9.5
8	1/4	14.2	3.78	3.30	9.3	16.0	9.5
10	3/8	17.6	4.01	3.50	12.6	17.5	9.5
15	1/2	21.8	4.67	4.09	15.8	22.5	9.5
20	3/4	27.2	4.90	4.27	21.0	24.0	12.5
25	1	33.9	5.69	4.98	26.7	28.5	12.5
32	1-1/4	42.7	6.07	5.28	35.1	30.0	12.5
40	1-1/2	48.8	6.35	5.54	40.9	32.0	12.5
50	2	61.2	6.93	6.04	52.5	41.0	16.0
65	2-1/2	73.9	8.76	7.67	62.7	43.0	16.0
80	3	89.8	9.52	8.30	78.0	44.5	16.0
100	4	115.2	10.69	9.35	102.3	48.0	19.0

6000Lb

6	1/8	10.8	3.96	3.43	4.0	16.0	9.5
8	1/4	14.2	4.60	4.01	6.4	16.0	9.5
10	3/8	17.6	5.03	4.37	9.2	17.5	9.5
15	1/2	21.8	5.97	5.18	11.8	22.5	9.5
20	3/4	27.2	6.96	6.04	15.6	24.0	12.5
25	1	33.9	7.92	6.93	20.7	28.5	12.5
32	1-1/4	42.7	7.92	6.93	29.5	30.0	12.5
40	1-1/2	48.8	8.92	7.80	34.0	32.0	12.5
50	2	61.2	10.92	9.50	42.9	41.0	16.0

9000Lb

15	1/2	21.8	9.35	8.18	6.4	22.5	9.5
20	3/4	27.2	9.78	8.56	11.1	24.0	12.5
25	1	33.9	11.38	9.96	15.2	28.5	12.5
32	1-1/4	42.7	12.14	10.62	22.8	30.0	12.5
40	1-1/2	48.8	12.70	11.12	28.0	32.0	12.5
50	2	61.2	13.84	12.12	38.2	41.0	16.0

(1) Average of socket Wall Thickness around periphery shall be no less than listed values. The minimum values are permitted in localized areas.

(2) Tolerance see page 20.

Threaded					
DN	Nom. Pipe Size	Length of Thread. (Min)		W	D
		B ^(*)	L2 ^(*)		

3000Lb

6	1/8	6.4	6.7	32	16
8	1/4	8.1	10.2	35	19
10	3/8	9.1	10.4	38	22
15	1/2	10.9	13.6	48	28
20	3/4	12.7	13.9	51	35
25	1	14.7	17.3	60	44
32	1-1/4	17.0	18.0	67	57
40	1-1/2	17.8	18.4	79	64
50	2	19.0	19.2	86	76
65	2-1/2	23.6	28.9	92	92
80	3	25.9	30.5	108	108
100	4	27.7	33.0	121	140

6000Lb

6	1/8	6.4	6.7	32	22
8	1/4	8.1	10.2	35	25
10	3/8	9.1	10.4	38	32
15	1/2	10.9	13.6	48	38
20	3/4	12.7	13.9	51	44
25	1	14.7	17.3	60	57
32	1-1/4	17.0	18.0	67	64
40	1-1/2	17.8	18.4	79	76
50	2	19.0	19.2	86	92
65	2-1/2	23.6	28.9	92	108
80	3	25.9	30.5	108	127
100	4	27.7	33.0	121	159

(*) Dimension B is minimum length of perfect thread. The length of useful thread (B plus threads with fully formed roots and flat crests) shall not be less than L2 (effective length of external thread) required by American National Standard for pipe threads (ANSI / ASME B1.20.1).

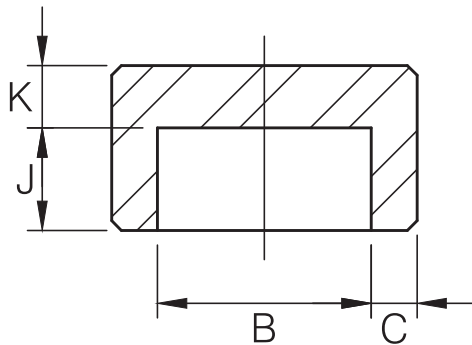

Dimensions are in millimeters.

Socket Welding						
DN	Nom. Pipe Size	B ⁽²⁾	C ⁽¹⁾		K (Min)	J (Min)
			(Avg)	(Min)		

3000Lb

6	1/8	10.8	3.18	3.18	4.8	9.5
8	1/4	14.2	3.78	3.30	4.8	9.5
10	3/8	17.6	4.01	3.50	4.8	9.5
15	1/2	21.8	4.67	4.09	6.4	9.5
20	3/4	27.2	4.90	4.27	6.4	12.5
25	1	33.9	5.69	4.98	9.6	12.5
32	1-1/4	42.7	6.07	5.28	9.6	12.5
40	1-1/2	48.8	6.35	5.54	11.2	12.5
50	2	61.2	6.93	6.04	12.7	16.0
65	2-1/2	73.9	8.76	7.67	15.7	16.0
80	3	89.8	9.52	8.30	19.0	16.0
100	4	115.2	10.69	9.35	22.4	19.0

6000Lb

6	1/8	10.8	3.96	3.43	6.4	9.5
8	1/4	14.2	4.60	4.01	6.4	9.5
10	3/8	17.6	5.03	4.37	6.4	9.5
15	1/2	21.8	5.97	5.18	7.9	9.5
20	3/4	27.2	6.96	6.04	7.9	12.5
25	1	33.9	7.92	6.93	11.2	12.5
32	1-1/4	42.7	7.92	6.93	11.2	12.5
40	1-1/2	48.8	8.92	7.80	12.7	12.5
50	2	61.2	10.92	9.50	15.7	16.0

9000Lb

15	1/2	21.8	9.35	8.18	11.2	9.5
20	3/4	27.2	9.78	8.56	12.7	12.5
25	1	33.9	11.38	9.96	14.2	12.5
32	1-1/4	42.7	12.14	10.62	14.2	12.5
40	1-1/2	48.8	12.70	11.12	15.7	12.5
50	2	61.2	13.84	12.12	19.0	16.0

(1) Average of socket Wall Thickness around periphery shall be no less than listed values. The minimum values are permitted in localized areas.

(2) Tolerance see page 20.

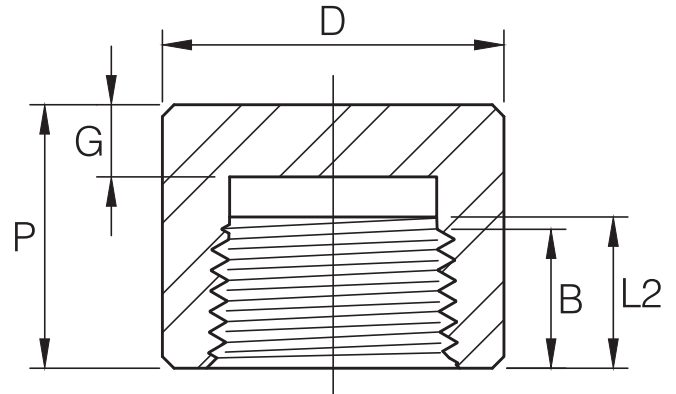

Dimensions are in millimeters.

Threaded						
DN	Nom. Pipe Size	Length of Thread. (Min)		P	D	G (Min)
		B ^(*)	L2 ^(*)			

3000Lb

6	1/8	6.4	6.7	19	16	4.8
8	1/4	8.1	10.2	25	19	4.8
10	3/8	9.1	10.4	25	22	4.8
15	1/2	10.9	13.6	32	28	6.4
20	3/4	12.7	13.9	37	35	6.4
25	1	14.7	17.3	41	44	9.7
32	1-1/4	17.0	18.0	44	57	9.7
40	1-1/2	17.8	18.4	44	64	11.2
50	2	19.0	19.2	48	76	12.7
65	2-1/2	23.6	28.9	60	92	15.7
80	3	25.9	30.5	65	108	19.0
100	4	27.7	33.0	68	140	22.4

6000Lb

8	1/4	8.1	10.2	27	25	6.4
10	3/8	9.1	10.4	27	32	6.4
15	1/2	10.9	13.6	33	38	7.9
20	3/4	12.7	13.9	38	44	7.9
25	1	14.7	17.3	43	57	11.2
32	1-1/4	17.0	18.0	46	64	11.2
40	1-1/2	17.8	18.4	48	76	12.7
50	2	19.0	19.2	51	92	15.7
65	2-1/2	23.6	28.9	64	108	19.0
80	3	25.9	30.5	68	127	22.4
100	4	27.7	33.0	75	159	28.4

(*) Dimension B is minimum length of perfect thread. The length of useful thread (B plus threads with fully formed roots and flat crests) shall not be less than L2 (effective length of external thread) required by American National Standard for pipe threads (ANSI / ASME B1.20.1).



SQUARE HEAD & ROUND HEAD PLUG

ASME B16.11-2011(Revision of ASME B16.11-2009)

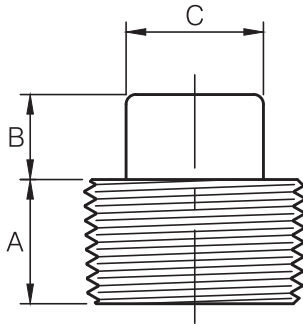

Dimensions are in millimeters.

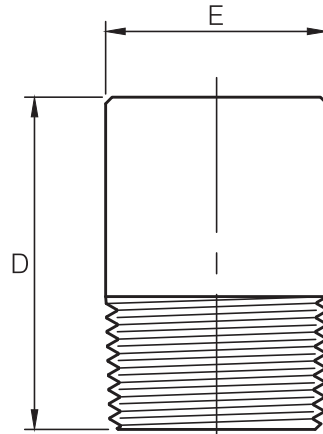

Dimensions are in millimeters.

Square Head Plug				
DN	Nom. Pipe Size	A (Min)	B (Min)	C (Min)
6	1/8	10	6	7.15
8	1/4	11	6	9.55
10	3/8	13	8	11.11
15	1/2	14	10	14.29
20	3/4	16	11	15.88
25	1	19	13	20.64
32	1-1/4	21	14	23.81
40	1-1/2	21	16	28.58
50	2	22	18	33.34 ⁽¹⁾
65	2-1/2	27	19	38.10
80	3	28	21	42.86
100	4	32	25	63.50

Round Head Plug			
DN	Nom. Pipe Size	E (Nom.)	D (Min)
6	1/8	10	35
8	1/4	14	41
10	3/8	18	41
15	1/2	21	44
20	3/4	27	44
25	1	33	51
32	1-1/4	43	51
40	1-1/2	48	51
50	2	60	64
65	2-1/2	73	70
80	3	89	70
100	4	114	76

(1) ASME B16.11-2011 SIZE 2" DATA "C", WE CONVERT INCH DATA INTO MILLIMETERS.

DIMENSIONAL TOLERANCE OF ASME B16.11

ASME B16.11-2011

Unit : mm

Item	Type of pipe fitting	Size							
		DN	6 to 8	10 to 20	25 to 50	65 to 100			
		NPS	1/8 to 1/4	3/8 to 3/4	1 to 2	2-1/2 to 4			
Bore diameter of socket (B)	All types of pipe fittings	+0.4 -0.0		+0.4 -0.0		+0.4 -0.0		+0.5 -0.0	
Bore diameter of fitting (D)		±0.7		±0.7		±0.7		±1.4	
Concentricity of bore (X)		± 0.8							
Coincidence of axes (Y)		1/200 Max							
Center to bottom of socket (A)	45° 90° Elbow Tee, Cross	± 1.0		± 1.5		± 2.0		± 2.5	
Bottom to bottom of socket (E)	Full Coupling	± 1.5		± 3.0		± 4.0		± 5.0	
Bottom to socket to opposite face (F)	Half Coupling	± 1.0		± 1.5		± 2.0		± 2.5	



HEX HEAD PLUG & BUSHING

ASME B16.11-2011 (Revision of ASME B16.11-2009)

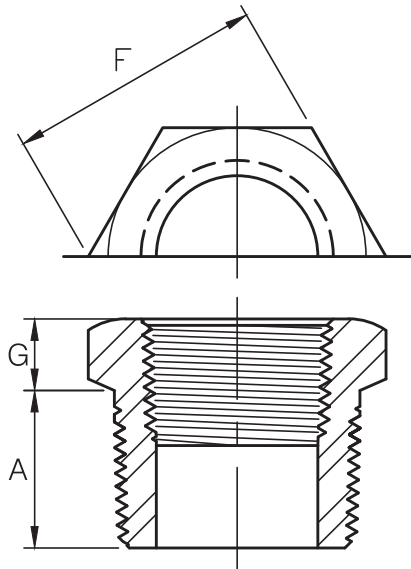
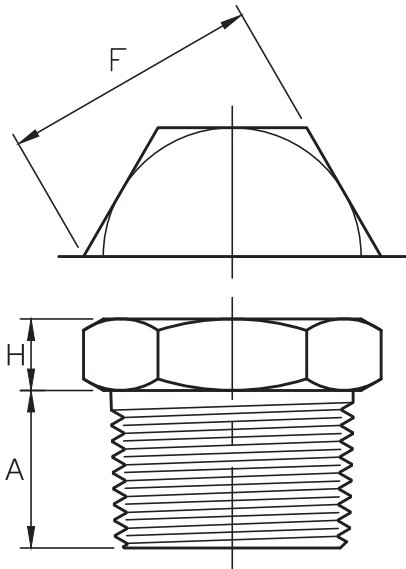

Dimensions are in millimeters.

Dimensions are in millimeters.

Hex Head Plug				
DN	Nom. Pipe Size	A (Min)	F (Nom.)	H (Min)
6	1/8	10	11.11	6
8	1/4	11	15.88	6
10	3/8	13	17.46	8
15	1/2	14	22.23	8
20	3/4	16	26.99	10
25	1	19	34.93	10
32	1-1/4	21	44.45	14
40	1-1/2	21	50.80	16
50	2	22	63.50	18
65	2-1/2	27	76.20	19
80	3	28	88.90	21
100	4	32	117.48	25

Hex Head Bushing				
DN	Nom. Pipe Size	A (Min)	F (Nom.)	G (Min)
8	1/4	11	15.88	3
10	3/8	13	17.46	4
15	1/2	14	22.23	5
20	3/4	16	26.99	6
25	1	19	34.93	6
32	1-1/4	21	44.45	7
40	1-1/2	21	50.80	8
50	2	22	63.50	9
65	2-1/2	27	76.20	10
80	3	28	88.90	10
100	4	32	117.48	13

(1) CAUTIONARY NOTE REGARDING HEX BUSHINGS.

Hex Head Bushings of one-size reduction should not be used in services where they might be subject to harmful loads and forces than internal pressures.



STREET ELBOW

ASME B16.11-2011(Revision of ASME B16.11-2009)

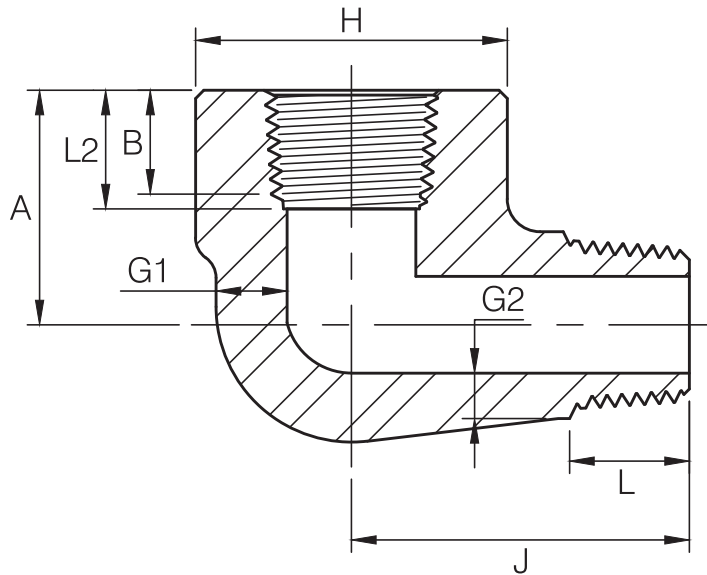

Dimensions are in millimeters.

DN	Nom. Pipe Size	H	A	J	G1 (Min)	G2 ⁽¹⁾ (Min)	B ⁽²⁾ (Min)	L2 ⁽²⁾ (Min)	L (Min)
----	----------------	---	---	---	-------------	----------------------------	---------------------------	----------------------------	------------

3000Lb

6	1/8	19	19	25	3.18	2.74	6.4	6.7	10.0
8	1/4	25	22	32	3.30	3.22	8.1	10.2	11.0
10	3/8	32	25	38	3.51	3.50	9.1	10.4	13.0
15	1/2	38	28	41	4.09	4.16	10.9	13.6	14.0
20	3/4	44	35	48	4.32	4.88	12.7	13.9	16.0
25	1	51	44	57	4.98	5.56	14.7	17.3	19.0
32	1-1/4	62	51	66	5.28	5.56	17.0	18.0	21.0
40	1-1/2	70	54	71	5.56	6.25	17.8	18.4	21.0
50	2	84	64	84	7.14	7.64	19.0	19.0	22.0

6000Lb

6	1/8	25	22	32	5.08	4.22	6.4	6.7	10.0
8	1/4	32	25	38	5.66	5.28	8.1	10.2	11.0
10	3/8	38	28	41	6.98	5.59	9.1	10.4	13.0
15	1/2	44	35	48	8.15	6.53	10.9	13.6	14.0
20	3/4	51	44	57	8.53	6.86	12.7	13.9	16.0
25	1	62	51	66	9.93	7.95	14.7	17.3	19.0
32	1-1/4	70	54	71	10.59	8.48	17.0	18.0	21.0
40	1-1/2	84	64	84	11.07	8.89	17.8	18.4	21.0
50	2	102	83	105	12.09	9.70	19.0	19.0	22.0

(1) Wall thickness before threading.

(2) Dimension B is minimum length of perfect thread. The length of useful thread (B plus threads with fully formed roots and flat crests) shall not be less than L2 (effective length of external thread) required by American National Standard for pipe threads (ANSI / ASME B1.20.1)

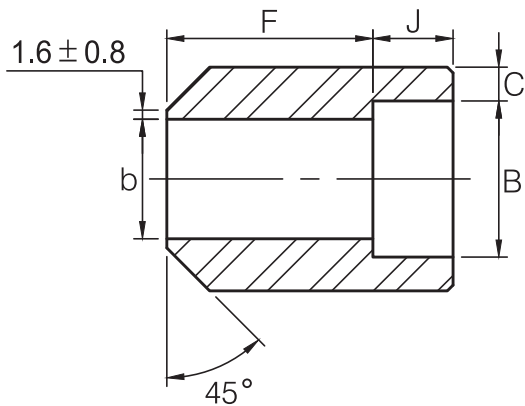

Dimensions are in millimeters.

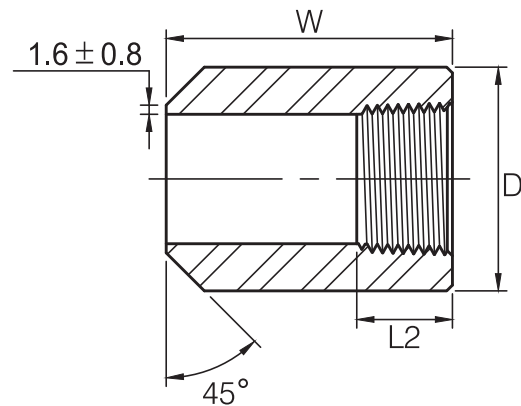

Dimensions are in millimeters.

Socket weld						
Nom. Pipe Size	DN	B (Min)	b	J (Min)	F	C (Min)

3000Lb						
1/8	6	10.7	6.8	10.0	28.0	3.2
1/4	8	14.1	9.2	10.0	32.0	3.3
3/8	10	17.6	12.5	11.0	34.0	3.5
1/2	15	21.8	15.5	13.0	38.0	4.1
3/4	20	27.4	21.0	13.0	38.0	4.3
1	25	34.1	26.5	16.0	35.0	5.0
1-1/2	40	49.0	40.5	19.0	32.0	5.6
2	50	61.0	52.0	22.0	29.0	6.1
2-1/2	65	73.8	62.0	22.0	29.0	7.7
3	80	89.7	78.0	22.0	29.0	8.3

6000Lb						
1/2	15	21.8	11.8	13.0	38.0	5.2
3/4	20	27.4	15.5	13.0	38.0	6.1
1	25	34.1	20.7	16.0	35.0	7.0
1-1/2	40	49.0	34.0	19.0	32.0	7.8
2	50	61.0	43.0	22.0	29.0	9.5
2-1/2	65	73.8	54.0	22.0	29.0	10.4
3	80	89.7	66.0	22.0	29.0	12.2

Threaded				
Nom. Pipe Size	DN	D	W	L2 (Min)

3000Lb				
1/8	6	16.0	38.0	6.70
1/4	8	19.0	41.0	10.21
3/8	10	22.0	45.0	10.36
1/2	15	29.0	51.0	13.56
3/4	20	35.0	51.0	13.86
1	25	45.0	51.0	17.34
1-1/2	40	64.0	51.0	18.38
2	50	76.0	51.0	19.22
2-1/2	65	95.0	51.0	28.89
3	80	110.0	57.0	30.48
4	100	140.0	64.0	33.02

6000Lb				
1/8	6	22.0	38.0	6.70
1/4	8	26.0	41.0	10.21
3/8	10	32.0	45.0	10.36
1/2	15	38.0	51.0	13.56
3/4	20	45.0	51.0	13.86
1	25	60.0	51.0	17.34
1-1/2	40	76.0	51.0	18.38
2	50	95.0	51.0	19.22

DIMENSIONAL TOLERANCE OF BS3799

BS3799-1974

Unit : mm

Item	Type of pipe fitting	DN	6~8	10~20	25~50	65~80
		NPS	1/8"~1/4"	3/8"~3/4"	1"~2"	2-1/2"~3"
Concentricity of bore (X)	All fittings	±0.8				
Coincidence of axes (Y)		± 1 / 200				
Bore diameter of fitting (b)	Boss & Hex Nipple	±0.4				±0.8
Bottom of socket to opposite face	Boss	±0.8	±1.5	±2.0	±2.5	



HEX NIPPLE

BS3799-1974

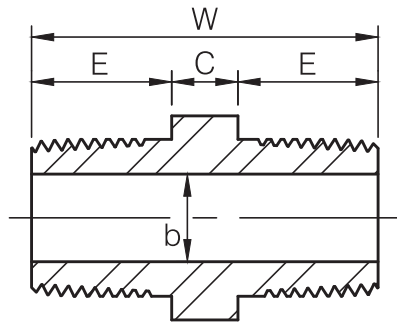

FULL SIZE

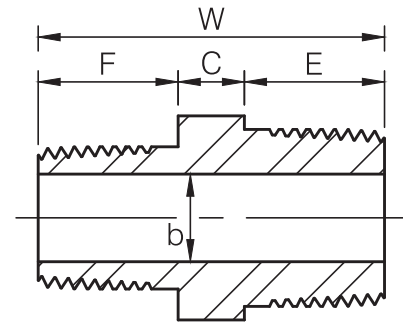
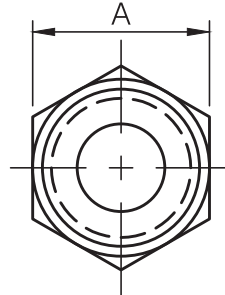

REDUCING SIZE

Dimensions are in millimeters.

Nominal Size				A (Min)	W (Min)	E (Min)	b ⁽¹⁾		C (Min)	F (Min)
Equal		Reducing					3M ⁽²⁾	6M ⁽²⁾		
In	DN	In	DN							
1/8	(6)	—	—	11	26	10	5	2	6	—
1/4	(8)	—	—	15	36	15	8	6	6	—
—	—	1/4 x 1/8	(8 x 6)	15	31	15	5	2	6	10
3/8	(10)	—	—	18	40	16	11	8	8	—
—	—	3/8 x 1/4	(10 x 8)	18	39	16	8	6	8	15
1/2	(15)	—	—	22	48	20	14	11	8	—
—	—	1/2 x 3/8	(15 x 10)	22	44	20	11	8	8	16
—	—	1/2 x 1/4	(15 x 8)	22	43	20	8	6	8	15
3/4	(20)	—	—	27	52	21	19	13	10	—
—	—	3/4 x 1/2	(20 x 15)	27	50	21	14	11	9	20
—	—	3/4 x 3/8	(20 x 10)	27	46	21	11	8	9	16
1	(25)	—	—	35	60	25	24	17	10	—
—	—	1 x 3/4	(25 x 20)	35	56	25	19	13	10	21
—	—	1 x 1/2	(25 x 15)	35	55	25	14	11	10	20
1-1/2	(40)	—	—	50	68	26	38	30	16	—
—	—	1-1/2 x 1	(40 x 25)	50	67	26	24	17	16	25
—	—	1-1/2 x 3/4	(40 x 20)	50	63	26	19	13	16	21
—	—	1-1/2 x 1/2	(40 x 15)	50	62	26	14	11	16	20
2	(50)	—	—	62	71	27	49	39	17	—
—	—	2 x 1-1/2	(50 x 40)	62	70	27	38	30	17	26
—	—	2 x 1	(50 x 25)	62	70	27	24	17	18	25
—	—	2 x 3/4	(50 x 20)	62	65	27	19	13	17	21
—	—	2 x 1/2	(50 x 15)	62	65	27	14	11	18	20

(1) Tolerance see page 23.

(2) 3M & 6M symbols denote 3000 & 6000 classes.



THREADED END UNION

MSS SP-83-2014

H-Thrd's
Minimum 4 Full Thrd's
Engagement Class 2A/2B Fit
ANSI B1.1

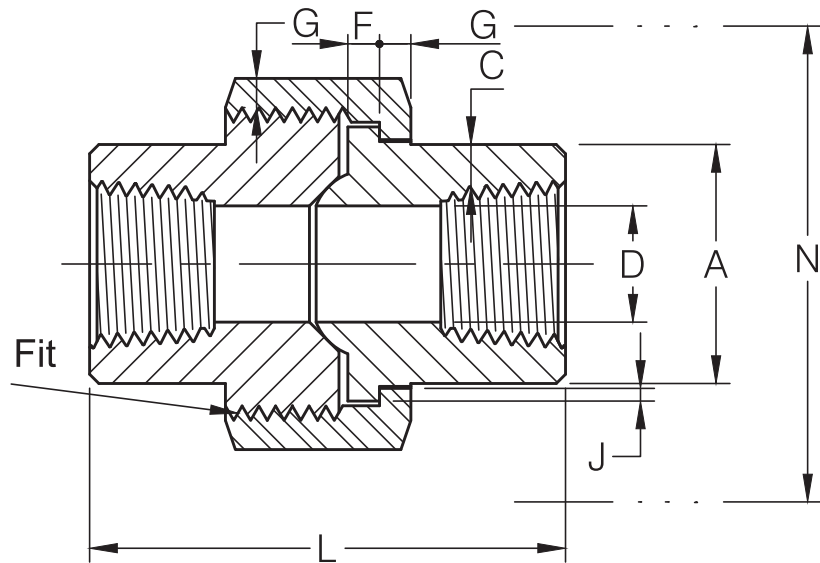

3000 Lb

Dimensions are in millimeters.

Nom. Pipe Size	Pipe End (Min) A	Wall (Min) C	Water Way Bore $D^{(1)}$	Male Flange (Min) F	Nut (Min) G	Thrds. Per 25.4mm H	Bearing (Min) J	Length Assem. Nom. L	Clear Assem. Nut N
1/8	14.7	2.41	8.43 6.43	3.18	3.18	16	1.24	41.4	50.8
1/4	19.0	3.02	11.13 9.45	3.18	3.18	16	1.24	41.4	50.8
3/8	22.9	3.20	14.27 13.51	3.43	3.43	14	1.37	46.0	55.9
1/2	27.7	3.73	17.86 17.07	3.68	3.68	14	1.50	49.0	58.4
3/4	33.5	3.91	23.01 21.39	4.06	4.06	11	1.68	56.9	66.0
1	41.4	4.55	28.98 27.74	4.57	4.45	11	1.85	62.0	78.7
1-1/4	50.5	4.85	37.69 35.36	5.33	5.21	10	2.13	71.1	94.0
1-1/2	57.2	5.08	43.54 41.20	5.84	5.59	10	2.31	76.5	111.8
2	70.1	5.54	55.58 52.12	6.60	6.35	10	2.69	86.1	132.1
2-1/2	85.3	7.01	66.27 64.31	7.49	7.11	8	3.07	102.4	149.9
3	102.4	7.62	82.55 77.27	8.26	8.00	8	3.53	109.0	175.3

(1) Upper and lower values for each size are the respective maximum and minimum dimensions.



SOCKET WELD END UNION

MSS SP-83-2014

H-Thrd's
Minimum 4 Full Thrd's
Engagement Class 2A / 2B Fit
ANSI B1.1

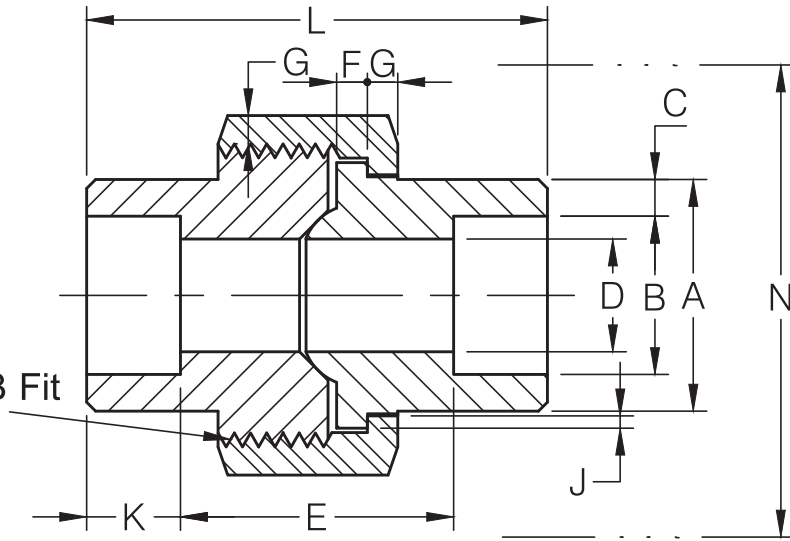

3000Lb

Dimensions are in millimeters.

Nom. Pipe Size	Pipe End (Min) A	Socket Bore Dia. B ⁽¹⁾	Socket Wall (Min) C	Water Way Bore D ⁽¹⁾	Laying Length E ⁽¹⁾	Male Flange (Min) F	Nut (Min) G	Thrds. Per 25.4mm H	Bearing (Min) J	Depth of Socket (Min) K	Length Assem. Nom. L	Clear Assem. Nut N
1/8	21.8	11.18 10.67	3.18	7.59 6.07	22.4 19.1	3.18	3.18	16	1.24	9.7	41.4	50.8
1/4	21.8	14.61 14.10	3.30	10.01 8.48	22.4 19.1	3.18	3.18	16	1.24	9.7	41.4	50.8
3/8	25.9	18.03 17.53	3.51	13.28 11.76	26.9 20.6	3.43	3.43	14	1.37	9.7	46.0	55.9
1/2	31.2	22.23 21.72	4.09	16.56 15.04	26.9 20.6	3.68	3.68	14	1.50	9.7	49.0	58.4
3/4	37.1	27.56 27.05	4.27	21.69 20.17	31.8 25.4	4.06	4.06	11	1.68	12.7	56.9	66.0
1	45.5	34.29 33.78	4.98	27.41 25.88	34.3 26.2	4.57	4.45	11	1.85	12.7	62.0	78.7
1-1/4	54.9	43.05 42.55	5.28	35.81 34.29	40.6 32.5	5.33	5.21	10	2.13	12.7	71.1	94.0
1-1/2	61.5	49.15 48.64	5.54	41.66 40.13	42.2 34.0	5.84	5.59	10	2.31	12.7	76.5	111.8
2	75.2	61.62 61.11	6.05	53.26 51.74	45.5 37.3	6.60	6.35	10	2.69	15.7	86.1	132.1
2-1/2	91.7	74.45 73.81	7.67	64.24 61.19	61.7 52.1	7.49	7.11	8	3.07	15.7	102.4	149.9
3	109.2	90.42 89.79	8.31	79.45 76.40	63.8 53.6	8.26	8.00	8	3.53	15.7	109.0	175.3

(1) Upper and lower values for each size are the respective maximum and minimum dimensions.



THREADED END UNION

MSS SP-83-2014

H-Thrd's
Minimum 4 Full Thrd's
Engagement Class 2A / 2B Fit
ANSI B1.1

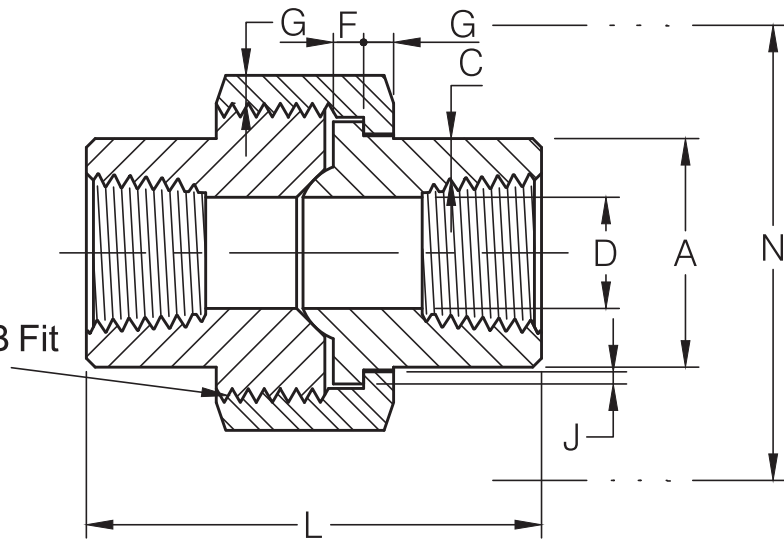

6000 Lb

Dimensions are in millimeters.

Nom. Pipe Size	Pipe End (Min) A	Wall (Min) C	Water Way Bore $D^{(1)}$	Male Flange (Min) F	Nut (Min) G	Thrds. Per 25.4mm H	Bearing (Min) J	Length Assem. Nom. L	Clear Assem. Nut N
1/8	16.5	3.15	8.43 3.20	3.18	3.18	16	1.24	41.4	50.8
1/4	21.1	3.68	11.13 5.59	3.43	3.43	14	1.37	46.0	55.9
3/8	25.1	4.01	14.27 8.36	3.68	3.68	14	1.50	49.0	58.4
1/2	31.0	4.78	17.86 11.02	4.06	4.06	11	1.68	56.9	66.0
3/4	37.8	5.56	23.01 14.78	4.57	4.45	11	1.85	62.0	78.7
1	46.2	6.35	28.98 19.94	5.33	5.21	10	2.13	71.1	94.0
1-1/4	54.9	6.35	37.69 28.70	5.84	5.59	10	2.31	76.5	111.8
1-1/2	62.5	7.14	43.54 33.22	6.60	6.35	10	2.69	86.1	132.1
2	77.7	8.74	55.58 42.09	7.49	7.11	8	3.07	102.4	149.9
2-1/2	92.2	9.53	66.27 53.21	8.26	8.00	8	3.53	109.0	175.3
3	111.3	11.13	82.55 65.89	10.19	10.19	8	4.06	158 ⁽²⁾	200.7

(1) Upper and lower values for each size are the respective maximum and minimum dimensions.

(2) This length size is 158mm by BothWell standards, and the actual length is 190.5mm from MSS SP-83 2014.



SOCKET WELD END UNION

MSS SP-83-2014

H-Thrd's
Minimum 4 Full Thrd's
Engagement Class 2A / 2B Fit
ANSI B1.1

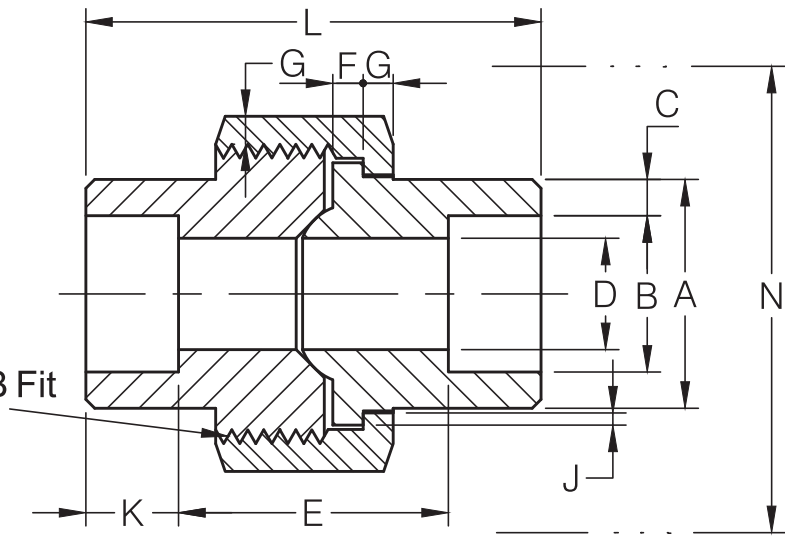

6000Lb

Dimensions are in millimeters.

Nom. Pipe Size	Pipe End (Min) A	Socket Bore Dia. B ⁽¹⁾	Socket Wall (Min) C	Water Way Bore D ⁽¹⁾	Laying Length E ⁽¹⁾	Male Flange (Min) F	Nut (Min) G	Thrds. Per 25.4mm H	Beaming (Min) J	Depth of Socket (Min) K	Length Assem. Nom. L	Clear Assem. Nut N
1/8	21.8	11.18 10.67	3.43	4.80 3.20	22.4 19.1	3.18	3.18	16	1.24	9.7	41.4	50.8
1/4	25.9	14.61 14.10	4.01	7.11 5.59	26.9 20.6	3.43	3.43	14	1.37	9.7	46.0	55.9
3/8	31.2	18.03 17.53	4.37	9.88 8.36	26.9 20.6	3.68	3.68	14	1.50	9.7	49.0	58.4
1/2	37.1	22.23 21.72	5.18	12.55 11.02	31.8 25.4	4.06	4.06	11	1.68	9.7	56.9	66.0
3/4	45.5	27.56 27.05	6.05	16.31 14.78	34.3 26.2	4.57	4.45	11	1.85	12.7	62.0	78.7
1	54.9	34.29 33.78	6.93	21.46 19.94	40.6 32.5	5.33	5.21	10	2.13	12.7	71.1	94.0
1-1/4	61.5	43.05 42.55	6.93	30.23 28.70	42.2 34.0	5.84	5.59	10	2.31	12.7	76.5	111.8
1-1/2	75.2	49.15 48.64	7.80	34.75 33.22	45.5 37.3	6.60	6.35	10	2.69	12.7	86.1	132.1
2	91.7	61.62 61.11	9.50	43.61 42.09	61.7 52.1	7.49	7.11	8	3.07	15.7	102.4	149.9
2-1/2	109.2	74.45 73.81	10.39	54.74 53.21	63.8 53.6	8.26	8.00	8	3.53	15.7	109.0	175.3

(1) Upper and lower values for each size are the respective maximum and minimum dimensions.



REDUCER INSERT

MSS SP-79-2011

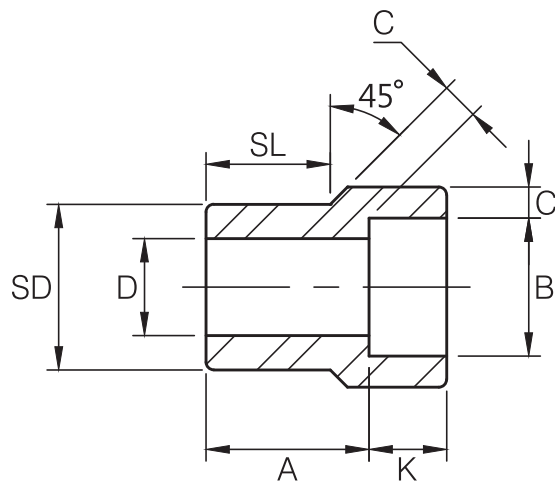

TYPE 1

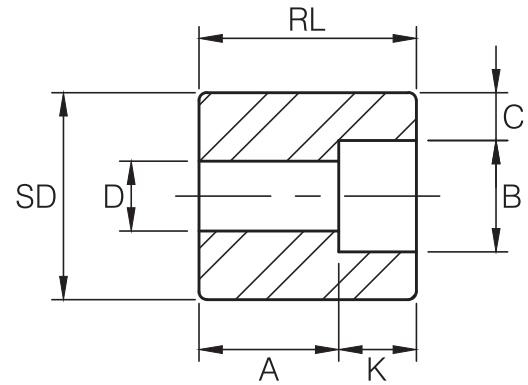

TYPE 2 ⁽¹⁾

Dimensions are in millimeters.

Nom. Pipe Size	Type ⁽²⁾		Socket		Shank Dia. SD	Laying Length A		Bore D		Wall (Min) C		Length			
	3M	6M	Dia. B	Depth (Min) K		3M	6M	3M	6M	3M	6M	SL		RL (Min)	
												3M	6M	3M	6M
3/8 × 1/4	1	1	14.4	9.5	17.1	19.0	21.3	9.2	6.3	3.78	4.60	14.2	15.7	—	—
1/2 × 3/8	1	1	17.8	9.5	21.3	20.6	23.1	12.5	9.1	4.01	5.03	15.7	15.7	—	—
1/2 × 1/4	1	1	14.4	9.5	21.3	20.6	20.6	9.2	6.3	3.78	4.60	15.7	15.7	—	—
3/4 × 1/2	1	1	22.0	9.5	26.7	22.4	25.4	15.8	11.7	4.67	5.97	17.5	19.0	—	—
3/4 × 3/8	2	1	17.8	9.5	26.7	15.7	22.4	12.5	9.1	4.01	5.03	—	19.0	26.9	—
3/4 × 1/4	2	2	14.4	9.5	26.7	17.5	22.4	9.2	6.3	3.78	4.60	—	—	26.9	32.0
1 × 3/4	1	1	27.4	12.5	33.4	23.9	28.4	20.9	15.5	4.90	6.96	19.0	20.6	—	—
1 × 1/2	2	1	22.0	9.5	33.4	15.7	28.4	15.8	11.7	4.67	5.97	—	20.6	28.4	—
1 × 3/8	2	2	17.8	9.5	33.4	17.5	22.4	12.5	9.1	4.01	5.03	—	—	28.4	33.2
1 × 1/4	2	2	14.4	9.5	33.4	19.0	23.9	9.2	6.3	3.78	4.60	—	—	28.4	33.2
1-1/4 × 1	1	1	34.1	12.5	42.2	25.4	30.2	26.6	20.7	5.69	7.92	20.6	22.4	—	—
1-1/4 × 3/4	2	2	27.4	12.5	42.2	17.5	20.6	20.9	15.5	4.90	6.96	—	—	31.7	34.7
1-1/4 × 1/2	2	2	22.0	9.5	42.2	19.0	22.4	15.8	11.7	4.67	5.97	—	—	31.7	34.7
1-1/4 × 3/8	2	2	17.8	9.5	42.2	20.6	23.9	12.5	9.1	4.01	5.03	—	—	31.7	34.7
1-1/4 × 1/4	2	2	14.4	9.5	42.2	22.4	25.4	9.2	6.3	3.78	4.60	—	—	31.7	34.7
1-1/2 × 1-1/4	1	1	42.9	12.5	48.2	28.4	35.0	35.0	29.4	6.07	7.92	22.4	25.4	—	—
1-1/2 × 1	2	1	34.1	12.5	48.2	17.5	29.2	26.6	20.7	5.69	7.92	—	25.4	33.2	—
1-1/2 × 3/4	2	2	27.4	12.5	48.2	19.0	25.4	20.9	15.5	4.90	6.96	—	—	33.2	39.6
1-1/2 × 1/2	2	2	22.0	9.5	48.2	20.6	26.9	15.8	11.7	4.67	5.97	—	—	33.2	39.6
1-1/2 × 3/8	2	2	17.8	9.5	48.2	22.4	28.4	12.5	9.1	4.01	5.03	—	—	33.2	39.6
2 × 1-1/2	1	1	49.0	12.5	60.3	31.8	38.9	40.8	33.9	6.35	8.92	25.4	28.7	—	—
2 × 1-1/4	2	2	42.9	12.5	60.3	20.6	23.9	35.0	29.4	6.07	7.92	—	—	38.1	41.1
2 × 1	2	2	34.1	12.5	60.3	22.4	25.4	26.6	20.7	5.69	7.92	—	—	38.1	41.1
2 × 3/4	2	2	27.4	12.5	60.3	23.9	26.9	20.9	15.5	4.90	6.96	—	—	38.1	41.1
2 × 1/2	2	2	22.0	9.5	60.3	25.4	28.4	15.8	11.7	4.67	5.97	—	—	38.1	41.1

(1) At the option of the manufacturer Type 2 Reducers may be furnished in Type 1 configuration.

(2) 3M & 6M symbols denote 3000 and 6000 classes.



REDUCER INSERT

MSS SP-79-2011

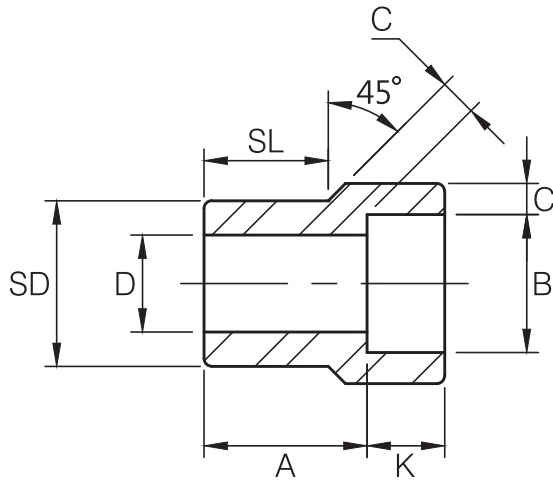

TYPE 1

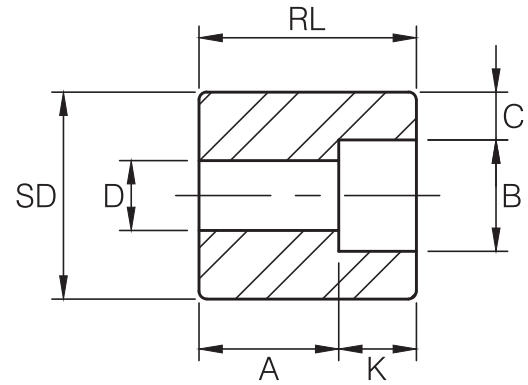

TYPE 2 ⁽¹⁾

(Continued)

Dimensions are in millimeters.

Nom. Pipe Size	Type ⁽²⁾		Socket		Shank Dia. SD	Laying Length A		Bore D		Wall (Min) C		Length			
	3M	6M	Dia. B	Depth (Min) K		3M	6M	3M	6M	3M	6M	SL		RL (Min)	
												3M	6M	3M	6M
2-1/2 × 2	1	1	61.4	16.0	73.0	46.0	42.7	52.4	42.8	6.93	10.92	38.1	31.8	—	—
2-1/2 × 1-1/2	2	2	49.0	12.5	73.0	35.0	35.0	40.8	33.9	6.35	8.92	—	—	53.8	53.8
2-1/2 × 1-1/4	2	2	42.9	12.5	73.0	36.6	36.6	35.0	29.4	6.07	7.92	—	—	53.8	53.8
2-1/2 × 1	2	2	34.1	12.5	73.0	38.1	38.1	26.6	20.7	5.69	7.92	—	—	53.8	53.8
2-1/2 × 3/4	2	2	27.4	12.5	73.0	39.6	38.1	20.9	15.5	4.90	6.96	—	—	53.8	53.8
3 × 2-1/2	1	1	74.1	16.0	88.9	38.1	57.2	62.7	54.0	8.76	11.91	31.8	44.4	—	—
3 × 2	2	2	61.4	16.0	88.9	25.4	31.8	52.4	42.8	6.93	10.92	—	—	47.4	53.8
3 × 1-1/2	2	2	49.0	12.5	88.9	28.4	31.8	40.8	33.9	6.35	8.92	—	—	47.4	53.8
3 × 1-1/4	2	2	42.9	12.5	88.9	30.2	31.8	35.0	29.4	6.07	7.92	—	—	47.4	53.8
3 × 1	2	2	34.1	12.5	88.9	31.8	31.8	26.6	20.7	5.69	7.92	—	—	47.4	53.8
4 × 3	2	—	90.0	16.0	114.3	33.3	—	77.9	—	9.52	—	—	—	60.4	—
4 × 2-1/2	2	—	74.1	16.0	114.3	38.1	—	62.7	—	8.76	—	—	—	60.4	—
4 × 2	2	—	61.4	16.0	114.3	38.1	—	52.4	—	6.93	—	—	—	60.4	—
4 × 1-1/2	2	—	49.0	12.5	114.3	41.1	—	40.8	—	6.35	—	—	—	60.4	—
4 × 1-1/4	2	—	42.9	12.5	114.3	42.9	—	35.0	—	6.07	—	—	—	60.4	—

(1) At the option of the manufacturer Type 2 Reducers may be furnished in Type 1 configuration.

(2) 3M & 6M symbols denote 3000 and 6000 classes.

DIMENSIONAL TOLERANCES OF REDUCER INSERT

MSS SP-79-2011

Unit : mm

	1/4	3/8	1/2	3/4	1	1-1/4	1-1/2	2	2-1/2	3	4
Laying Length (A)	⊗	+1.5 -0.0			+2.0 -0.0			+2.5 -0.0			
Socket Dia (B)	±0.20								+0.3 -0.2		⊗
Bore (D)	±0.8								±1.5		⊗
Shank Dia (SD)	⊗	±0.25						±0.50			±0.8
Shank Length (SL)	⊗	+0.0 -1.5			+0.0 -2.0			+0.0 -2.5			



SWAGED NIPPLE

MSS SP-95-2014

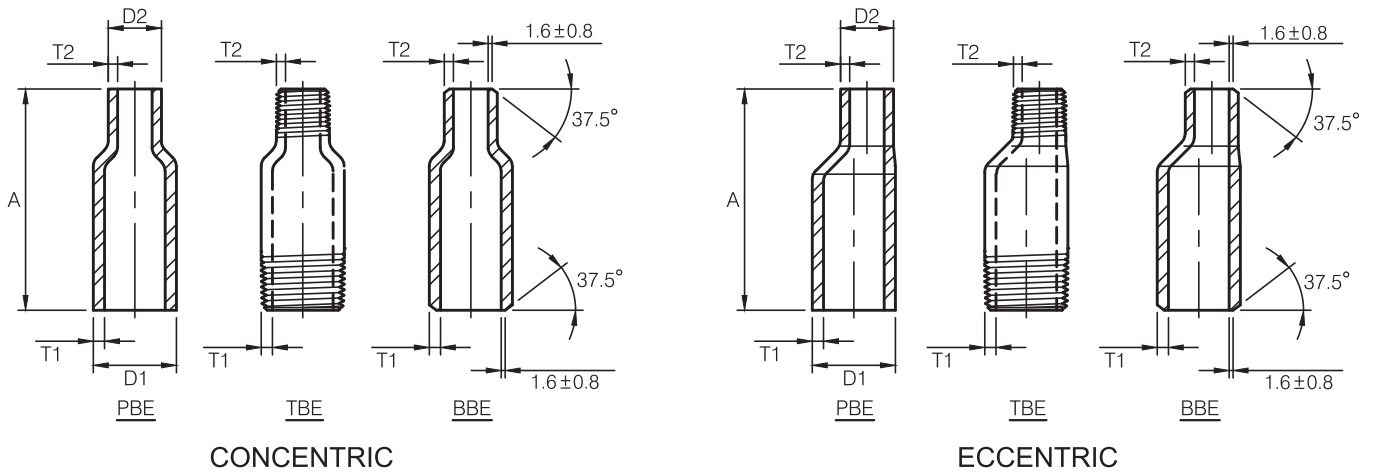

Dimensions are in millimeters.

Nom. Pipe Size	Outside Diameter		End to End "A"	Wall Thickness							
	Large End D1	Small End D2		T1				T2			
				Sch40 (STD)	Sch80 (XS)	Sch160	XXS	Sch40 (STD)	Sch80 (XS)	Sch160	XXS
1/4 × 1/8	13.7	10.3	57	2.2	3.0	3.7	6.1	1.7	2.4	—	—
3/8 × 1/8	17.1	10.3	64	2.3	3.2	4.0	6.4	1.7	2.4	—	—
3/8 × 1/4	17.1	13.7	64	2.3	3.2	4.0	6.4	2.2	3.0	—	—
1/2 × 1/8	21.3	10.3	70	2.8	3.7	4.8	7.5	1.7	2.4	—	—
1/2 × 1/4	21.3	13.7	70	2.8	3.7	4.8	7.5	2.2	3.0	—	—
1/2 × 3/8	21.3	17.1	70	2.8	3.7	4.8	7.5	2.3	3.2	—	—
3/4 × 1/8	26.7	10.3	76	2.9	3.9	5.6	7.8	1.7	2.4	—	—
3/4 × 1/4	26.7	13.7	76	2.9	3.9	5.6	7.8	2.2	3.0	—	—
3/4 × 3/8	26.7	17.1	76	2.9	3.9	5.6	7.8	2.3	3.2	—	—
3/4 × 1/2	26.7	21.3	76	2.9	3.9	5.6	7.8	2.8	3.7	4.8	7.5
1 × 1/8	33.4	10.3	89	3.4	4.5	6.4	9.1	1.7	2.4	—	—
1 × 1/4	33.4	13.7	89	3.4	4.5	6.4	9.1	2.2	3.0	—	—
1 × 3/8	33.4	17.1	89	3.4	4.5	6.4	9.1	2.3	3.2	—	—
1 × 1/2	33.4	21.3	89	3.4	4.5	6.4	9.1	2.8	3.7	4.8	7.5
1 × 3/4	33.4	26.7	89	3.4	4.5	6.4	9.1	2.9	3.9	5.6	7.8
1-1/4 × 1/8	42.2	10.3	102	3.6	4.9	6.4	9.7	1.7	2.4	—	—
1-1/4 × 1/4	42.2	13.7	102	3.6	4.9	6.4	9.7	2.2	3.0	—	—
1-1/4 × 3/8	42.2	17.1	102	3.6	4.9	6.4	9.7	2.3	3.2	—	—
1-1/4 × 1/2	42.2	21.3	102	3.6	4.9	6.4	9.7	2.8	3.7	4.8	7.5
1-1/4 × 3/4	42.2	26.7	102	3.6	4.9	6.4	9.7	2.9	3.9	5.6	7.8
1-1/4 × 1	42.2	33.4	102	3.6	4.9	6.4	9.7	3.4	4.5	6.4	9.1
1-1/2 × 1/8	48.3	10.3	114	3.7	5.1	7.1	10.2	1.7	2.4	—	—
1-1/2 × 1/4	48.3	13.7	114	3.7	5.1	7.1	10.2	2.2	3.0	—	—
1-1/2 × 3/8	48.3	17.1	114	3.7	5.1	7.1	10.2	2.3	3.2	—	—
1-1/2 × 1/2	48.3	21.3	114	3.7	5.1	7.1	10.2	2.8	3.7	4.8	7.5
1-1/2 × 3/4	48.3	26.7	114	3.7	5.1	7.1	10.2	2.9	3.9	5.6	7.8
1-1/2 × 1	48.3	33.4	114	3.7	5.1	7.1	10.2	3.4	4.5	6.4	9.1
1-1/2 × 1-1/4	48.3	42.2	114	3.7	5.1	7.1	10.2	3.6	4.9	6.4	9.7
2 × 1/8	60.3	10.3	165	3.9	5.5	8.7	11.1	1.7	2.4	—	—
2 × 1/4	60.3	13.7	165	3.9	5.5	8.7	11.1	2.2	3.0	—	—
2 × 3/8	60.3	17.1	165	3.9	5.5	8.7	11.1	2.3	3.2	—	—
2 × 1/2	60.3	21.3	165	3.9	5.5	8.7	11.1	2.8	3.7	4.8	7.5
2 × 3/4	60.3	26.7	165	3.9	5.5	8.7	11.1	2.9	3.9	5.6	7.8
2 × 1	60.3	33.4	165	3.9	5.5	8.7	11.1	3.4	4.5	6.4	9.1
2 × 1-1/4	60.3	42.2	165	3.9	5.5	8.7	11.1	3.6	4.9	6.4	9.7
2 × 1-1/2	60.3	48.3	165	3.9	5.5	8.7	11.1	3.7	5.1	7.1	10.2
2-1/2 × 1/8	73.0	10.3	178	5.2	7.0	9.5	14.0	1.7	2.4	—	—
2-1/2 × 1/4	73.0	13.7	178	5.2	7.0	9.5	14.0	2.2	3.0	—	—
2-1/2 × 3/8	73.0	17.1	178	5.2	7.0	9.5	14.0	2.3	3.2	—	—
2-1/2 × 1/2	73.0	21.3	178	5.2	7.0	9.5	14.0	2.8	3.7	4.8	7.5
2-1/2 × 3/4	73.0	26.7	178	5.2	7.0	9.5	14.0	2.9	3.9	5.6	7.8
2-1/2 × 1	73.0	33.4	178	5.2	7.0	9.5	14.0	3.4	4.5	6.4	9.1



SWAGED NIPPLE

MSS SP-95-2014

(Continued)

Dimensions are in millimeters.

Nom. Pipe Size	Outside Diameter		End to End "A"	Wall Thickness							
	Large End D1	Small End D2		T1				T2			
				Sch40 (STD)	Sch80 (XS)	Sch160	XXS	Sch40 (STD)	Sch80 (XS)	Sch160	XXS
2-1/2 × 1-1/4	73.0	42.2	178	5.2	7.0	9.5	14.0	3.6	4.9	6.4	9.7
2-1/2 × 1-1/2	73.0	48.3	178	5.2	7.0	9.5	14.0	3.7	5.1	7.1	10.2
2-1/2 × 2	73.0	60.3	178	5.2	7.0	9.5	14.0	3.9	5.5	8.7	11.1
3 × 1/8	88.9	10.3	203	5.5	7.6	11.1	15.2	1.7	2.4	—	—
3 × 1/4	88.9	13.7	203	5.5	7.6	11.1	15.2	2.2	3.0	—	—
3 × 3/8	88.9	17.1	203	5.5	7.6	11.1	15.2	2.3	3.2	—	—
3 × 1/2	88.9	21.3	203	5.5	7.6	11.1	15.2	2.8	3.7	4.8	7.5
3 × 3/4	88.9	26.7	203	5.5	7.6	11.1	15.2	2.9	3.9	5.6	7.8
3 × 1	88.9	33.4	203	5.5	7.6	11.1	15.2	3.4	4.5	6.4	9.1
3 × 1-1/4	88.9	42.2	203	5.5	7.6	11.1	15.2	3.6	4.9	6.4	9.7
3 × 1-1/2	88.9	48.3	203	5.5	7.6	11.1	15.2	3.7	5.1	7.1	10.2
3 × 2	88.9	60.3	203	5.5	7.6	11.1	15.2	3.9	5.5	8.7	11.1
3 × 2-1/2	88.9	73.0	203	5.5	7.6	11.1	15.2	5.2	7.0	9.5	14.0
3-1/2 × 1/8	101.6	10.3	203	5.7	8.1	—	—	1.7	2.4	—	—
3-1/2 × 1/4	101.6	13.7	203	5.7	8.1	—	—	2.2	3.0	—	—
3-1/2 × 3/8	101.6	17.1	203	5.7	8.1	—	—	2.3	3.2	—	—
3-1/2 × 1/2	101.6	21.3	203	5.7	8.1	—	—	2.8	3.7	4.8	7.5
3-1/2 × 3/4	101.6	26.7	203	5.7	8.1	—	—	2.9	3.9	5.6	7.8
3-1/2 × 1	101.6	33.4	203	5.7	8.1	—	—	3.4	4.5	6.4	9.1
3-1/2 × 1-1/4	101.6	42.2	203	5.7	8.1	—	—	3.6	4.9	6.4	9.7
3-1/2 × 1-1/2	101.6	48.3	203	5.7	8.1	—	—	3.7	5.1	7.1	10.2
3-1/2 × 2	101.6	60.3	203	5.7	8.1	—	—	3.9	5.5	8.7	11.1
3-1/2 × 2-1/2	101.6	73.0	203	5.7	8.1	—	—	5.2	7.0	9.5	14.0
3-1/2 × 3	101.6	88.9	203	5.7	8.1	—	—	5.5	7.6	11.1	15.2
4 × 1/4	114.3	13.7	229	6.0	8.6	13.5	17.1	2.2	3.0	—	—
4 × 3/8	114.3	17.1	229	6.0	8.6	13.5	17.1	2.3	3.2	—	—
4 × 1/2	114.3	21.3	229	6.0	8.6	13.5	17.1	2.8	3.7	4.8	7.5
4 × 3/4	114.3	26.7	229	6.0	8.6	13.5	17.1	2.9	3.9	5.6	7.8
4 × 1	114.3	33.4	229	6.0	8.6	13.5	17.1	3.4	4.5	6.4	9.1
4 × 1-1/4	114.3	42.2	229	6.0	8.6	13.5	17.1	3.6	4.9	6.4	9.7
4 × 1-1/2	114.3	48.3	229	6.0	8.6	13.5	17.1	3.7	5.1	7.1	10.2
4 × 2	114.3	60.3	229	6.0	8.6	13.5	17.1	3.9	5.5	8.7	11.1
4 × 2-1/2	114.3	73.0	229	6.0	8.6	13.5	17.1	5.2	7.0	9.5	14.0
4 × 3	114.3	88.9	229	6.0	8.6	13.5	17.1	5.5	7.6	11.1	15.2
4 × 3-1/2	114.3	101.6	229	6.0	8.6	13.5	17.1	5.7	8.1	—	—

(1) Wall Thickness (T1, T2) in accordance with ASME B36.10M.

PBE: PLAIN BOTH ENDS
PSE: PLAIN SMALL END
PLE: PLAIN LARGE END

BBE: BEVEL BOTH ENDS
BSE: BEVEL SMALL END
BLE: BEVEL LARGE END

TBE: THREAD BOTH ENDS
TSE: THREAD SMALL END
TLE: THREAD LARGE END

DIMENSIONAL TOLERANCES OF SWAGED NIPPLES

MSS SP-95-2014

Unit : mm

Nominal Pipe Size (Inch)	Overall Length	Outside Diameter at End		Fitting Wall Thickness (see Note 1)
		Square Cut Ends	Other End Connections	
1/8 ~ 3/8	±1.5	+0.4 -0.8	±0.8	Not less than 87.5% of Nominal Wall Thickness
1/2 ~ 1-1/2	±1.5	+0.4 -0.8	+1.5 -0.8	
2 ~ 2-1/2	±3.0	±0.8	+1.5 -0.8	
3 ~ 4	±3.0	±0.8	±1.5	

Note 1 : Prior to threading or grooving



BULL PLUG

MSS SP-95-2014

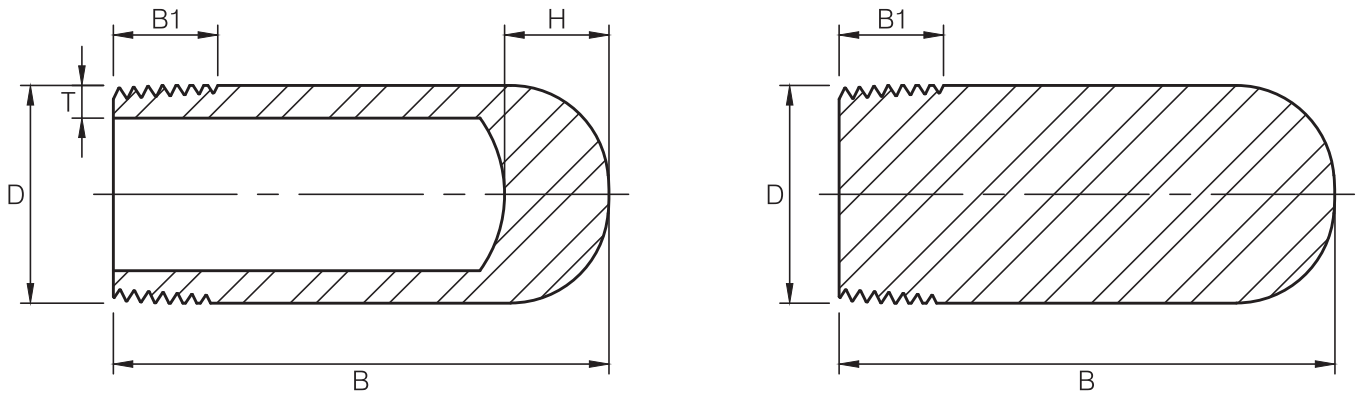

Dimensions are in millimeters.

Nom. Pipe Size	D	B	B1	T (Min)				H
				Sch 40/STD	Sch 80/XS (3M)	Sch160 (6M)	XXS	
1/8	10.3	51	9.5	1.73	2.41	—	—	14
1/4	13.7	51	11.0	2.24	3.02	—	—	14
3/8	17.1	57	12.5	2.31	3.20	—	—	14
1/2	21.3	64	14.5	2.77	3.73	4.78	7.47	14
3/4	26.7	70	16.0	2.87	3.91	5.56	7.82	18
1	33.4	76	19.0	3.38	4.55	6.35	9.09	18
1-1/4	42.2	83	20.5	3.56	4.85	6.35	9.70	18
1-1/2	48.3	89	20.5	3.68	5.08	7.14	10.15	18
2	60.3	102	22.0	3.91	5.54	8.74	11.07	20
2-1/2	73.0	127	27.0	5.16	7.01	9.53	14.02	20
3	88.9	152	28.5	5.49	7.62	11.13	15.24	20
4	114.3	178	32.0	6.02	8.56	13.49	17.12	20

(1) Thread in accordance with ASME B1.20.1

(2) Wall Thickness (T Min.) in accordance with ASME B36.10M



THREADED END 90° BRANCH OUTLET

MSS SP-97-2012

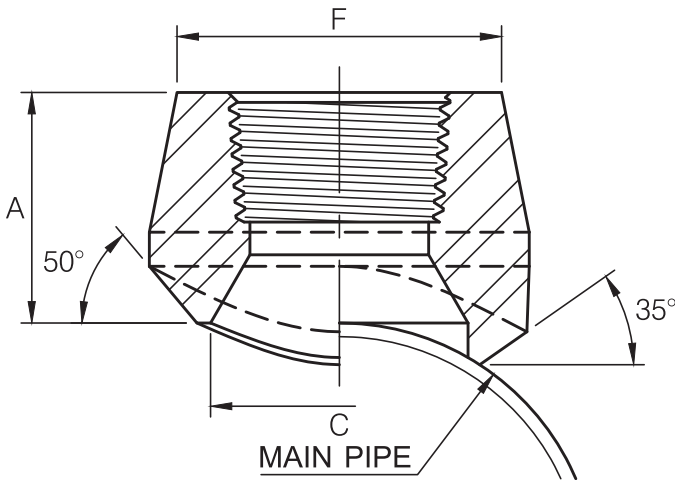

REDUCING WAY

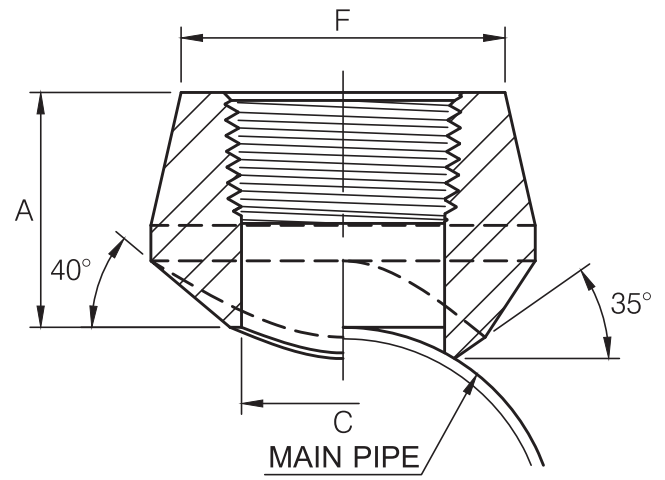

STRAIGHT WAY

Dimensions are in millimeters.

Dimensions are in millimeters.

Reducing way			
OutLet Pipe (in)	A	C	F

3000Lb			
1/8	19.0	13.7	17.3
1/4	19.0	13.7	22.0
3/8	20.6	17.1	25.9
1/2	25.4	21.3	31.4
3/4	26.9	26.7	37.1
1	33.3	33.4	45.5
1-1/4	33.3	42.2	57.0
1-1/2	35.0	48.3	64.0
2	38.1	60.3	76.0
2-1/2	46.0	73.0	92.0
3	50.8	88.9	109.2
4	57.2	114.3	140.0

Straight way			
OutLet Pipe (in)	A	C	F

3000Lb			
1/4	19.0	11.5	22.0
3/8	20.6	14.5	25.9
1/2	25.4	16.5	31.4
3/4	26.9	21.5	37.1
1	33.3	27.2	45.5
1-1/4	33.3	36.0	57.0
1-1/2	35.0	42.0	64.0
2	38.1	53.0	76.0
2-1/2	46.0	65.0	92.0
3	50.8	80.0	109.2
4	57.2	104.0	140.0

(1) Thread in accordance with ASME B1.20.1

6000Lb

1/2	31.8	16.6	33.9
3/4	36.6	21.2	41.2
1	39.6	27.0	49.9
1-1/4	41.1	35.8	58.6
1-1/2	42.3	41.2	66.7
2	52.3	51.6	83.2

- (1) Thread in accordance with ASME B1.20.1.
- (2) 3000LB outlet size 4 and less fit a number of run pipe sizes and the fitting are marked accordingly.
See page 38 for conventional run pipe size combination.

DIMENSIONAL TOLERANCE

MSS SP-97-2012

Unit : mm

Item	1/8"~3/4"	1"~4"
Face of fitting to crotch (A)	±0.8	±1.6



SOCKET WELDING END 90° BRANCH OUTLET

MSS SP-97-2012

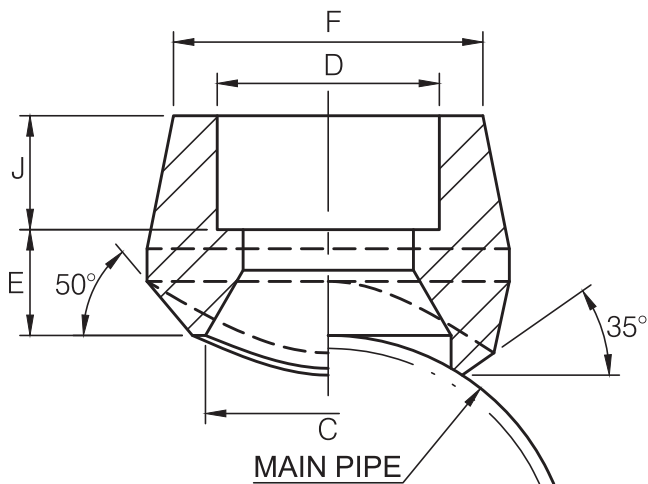

REDUCING WAY

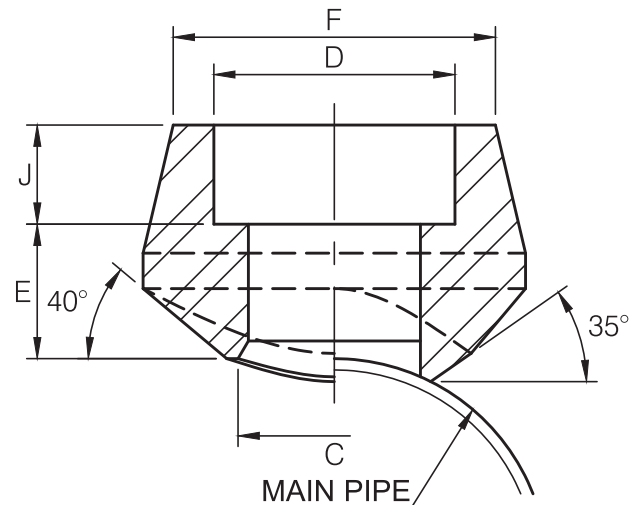

STRAIGHT WAY

Dimensions are in millimeters.

Reducing way					
OutLet Pipe (in)	C	D	F	J (Min)	E (Max)

3000Lb					
1/8	13.7	10.8	22.0	9.5	11.0
1/4	13.7	14.2	22.0	9.5	11.0
3/8	19.1	17.6	25.9	9.5	13.0
1/2	21.3	21.8	31.4	9.5	16.0
3/4	26.7	27.2	37.1	12.5	16.0
1	33.4	33.9	45.5	12.5	23.0
1-1/4	42.2	42.7	57.0	12.5	23.0
1-1/2	48.3	48.8	64.0	12.5	24.0
2	60.3	61.2	76.0	16.0	24.0
2-1/2	73.2	73.9	92.0	16.0	26.0
3	88.9	89.8	109.2	16.0	31.0
4	114.3	115.2	140.0	19.0	31.0

6000Lb					
1/2	16.6	21.8	38.0	9.5	24.0
3/4	21.2	27.2	44.0	12.5	26.0
1	27.0	33.9	57.0	12.5	29.0
1-1/4	35.8	42.7	64.0	12.5	31.0
1-1/2	41.2	48.8	76.0	12.5	32.0
2	51.6	61.2	92.0	16.0	37.0

- (1) Socket in accordance with ASME B16.11.
 (2) 3000LB Outlet size 4 and less fit a number of run pipe sizes and the fitting are marked accordingly.
 See page 38 for conventional run pipe size combination.

Dimensions are in millimeters.

Straight way					
OutLet Pipe (in)	C	D	F	J (Min)	E (Max)

3000Lb					
1/4	11.5	14.2	22.0	9.5	11.0
3/8	14.5	17.6	25.9	9.5	13.0
1/2	16.5	21.8	31.4	9.5	16.0
3/4	21.5	27.2	37.1	12.5	16.0
1	27.2	33.9	45.5	12.5	23.0
1-1/4	36.0	42.7	57.0	12.5	23.0
1-1/2	42.0	48.8	64.0	12.5	24.0
2	53.0	61.2	76.0	16.0	24.0
2-1/2	65.0	73.9	92.0	16.0	26.0
3	80.0	89.8	109.2	16.0	31.0
4	104.0	115.2	140.0	19.0	31.0

- (1) Socket in accordance with ASME B16.11 .



BUTT WELDING END 90° BRANCH OUTLET

MSS SP-97-2012

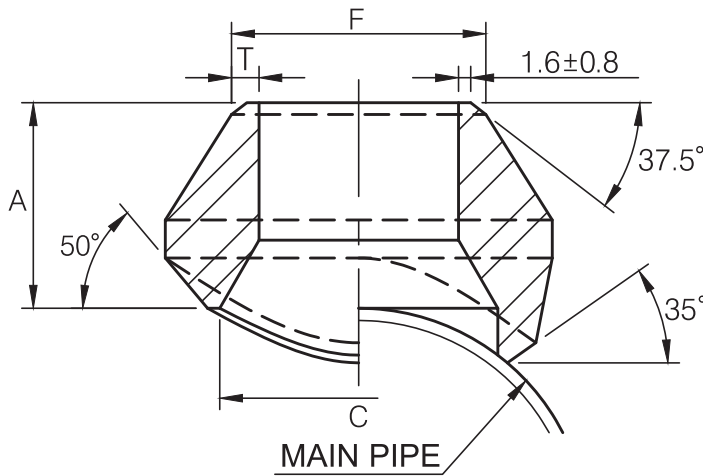

REDUCING WAY

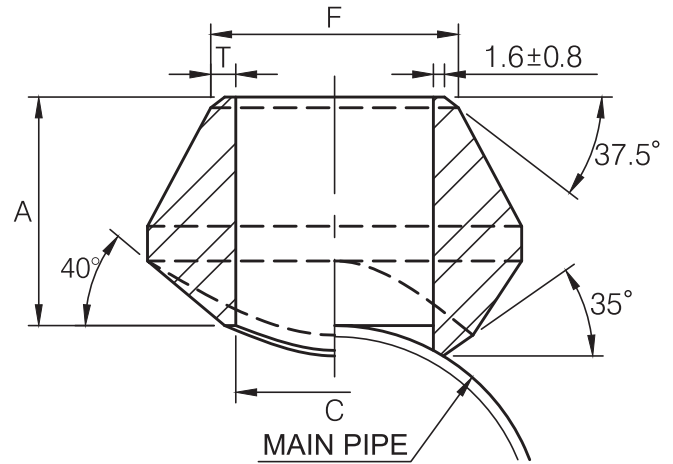

STRAIGHT WAY

STANDARD

Dimensions are in millimeters.

Reducing way				
OutLet Pipe (in)	A	C	F	T
1/8	15.7	13.7	10.3	1.73
1/4	15.7	13.7	13.7	2.24
3/8	19.1	17.1	17.1	2.31
1/2	19.1	21.3	21.3	2.77
3/4	22.4	26.7	26.7	2.87
1	26.9	33.4	33.4	3.38
1-1/4	31.8	42.2	42.2	3.56
1-1/2	33.3	48.3	48.3	3.68
2	38.1	60.3	60.3	3.91
2-1/2	41.1	73.0	73.0	5.16
3	44.4	88.9	88.9	5.49
3-1/2	47.8	101.6	101.6	5.74
4	50.8	114.3	114.3	6.02
5	57.2	141.3	141.3	6.55
6	60.4	168.3	168.3	7.11
8	69.8	219.3	219.3	8.11
10	77.7	273.1	273.1	9.27
12	85.9	323.9	323.9	9.53
14	88.9	355.6	355.6	9.53
16	93.7	406.4	406.4	9.53
18	96.8	457.2	457.2	9.53
20	101.6	508.0	508.0	9.53
24	115.8	609.6	609.6	9.53

Dimensions are in millimeters.

Straight way				
OutLet Pipe (in)	A	C	F	T
1/4	15.7	11.5	13.7	2.24
3/8	19.1	14.5	17.1	2.31
1/2	19.1	16.5	21.3	2.77
3/4	22.4	21.5	26.7	2.87
1	26.9	27.2	33.4	3.38
1-1/4	31.8	36.0	42.2	3.56
1-1/2	33.3	42.0	48.3	3.68
2	38.1	53.0	60.3	3.91
2-1/2	41.1	65.0	73.0	5.16
3	44.4	80.0	88.9	5.49
4	50.8	104.0	114.3	6.02

(1) Weld Bevel in accordance with ASME B16.25.

DIMENSIONAL TOLERANCE

MSS SP-97-2012

Unit : mm

Item	1/8"~3/4"	1"~4"	5"~12"	14"~24"
Face of fitting to crotch (A)	±0.8	±1.6	±3.2	±4.8

- (1) Weld Bevel in accordance with ASME B16.25.
- (2) Outlet size 4 and less fit a number of run pipe sizes and the fittings are marked accordingly.
See page 38 for conventional run pipe size combination.
- (3) Outlet sizes 5 and up order to specific size combination.



BUTT WELDING END 90° BRANCH OUTLET

MSS SP-97-2012

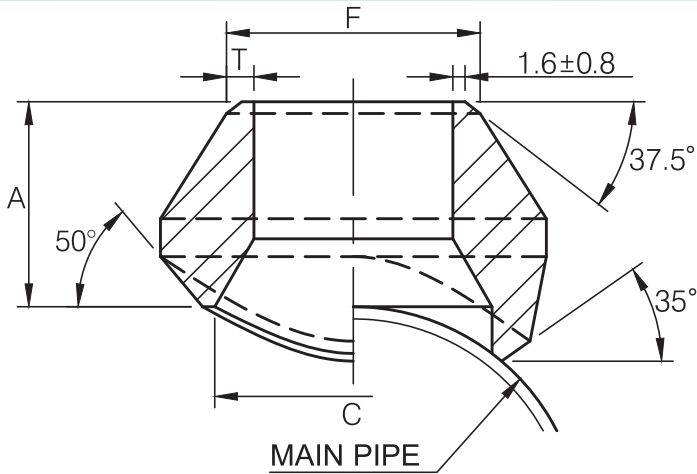

REDUCING WAY

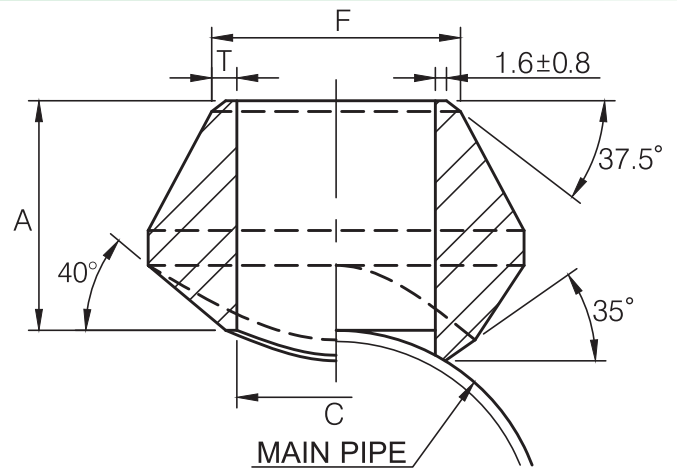

STRAIGHT WAY

EXTRA STRONG

Dimensions are in millimeters.

Reducing way				
OutLet Pipe (in)	A	C	F	T
1/8	15.7	13.7	10.3	2.41
1/4	15.7	13.7	13.7	3.02
3/8	19.1	17.1	17.1	3.20
1/2	19.1	21.3	21.3	3.73
3/4	22.4	26.7	26.7	3.91
1	26.9	33.4	33.4	4.55
1-1/4	31.8	42.2	42.2	4.85
1-1/2	33.3	48.3	48.3	5.08
2	38.1	60.3	60.3	5.54
2-1/2	41.1	73.0	73.0	7.01
3	44.4	88.9	88.9	7.62
3-1/2	47.8	101.6	101.6	8.56
4	50.8	114.3	114.3	8.56
5	57.2	141.3	141.3	9.53
6	77.7	168.3	168.3	10.97
8	98.6	219.3	219.3	12.70
10	93.7	273.1	273.1	12.70
12	103.1	323.9	323.9	12.70
14	100.1	355.6	355.6	12.70
16	106.2	406.4	406.4	12.70
18	111.2	457.2	457.2	12.70
20	119.1	508.0	508.0	12.70
24	139.7	609.6	609.6	12.70

Dimensions are in millimeters.

Straight way				
OutLet Pipe (in)	A	C	F	T
1/4	15.7	11.5	13.7	3.02
3/8	19.1	14.5	17.1	3.20
1/2	19.1	16.5	21.3	3.73
3/4	22.4	21.5	26.7	3.91
1	26.9	27.2	33.4	4.55
1-1/4	31.8	36.0	42.2	4.85
1-1/2	33.3	42.0	48.3	5.08
2	38.1	53.0	60.3	5.54
2-1/2	41.1	65.0	73.0	7.01
3	44.4	80.0	88.9	7.62
4	50.8	104.0	114.3	8.56

(1) Weld Bevel in Accordance with ASME B16.25.

DIMENSIONAL TOLERANCE

MSS SP-97-2012

Unit : mm

Item	1/8"~3/4"	1"~4"	5"~12"	14"~24"
Face of fitting to crotch (A)	±0.8	±1.6	±3.2	±4.8

(1) Weld Bevel in accordance with ASME B16.25

(2) Outlet size 4 and less fit a number of run pipe sizes and the fittings are marked accordingly.

See page 38 for conventional run pipe size combination.

(3) Outlet sizes 5 and up order to specific size combination.



BUTT WELDING END 90° BRANCH OUTLET

MSS SP-97-2012

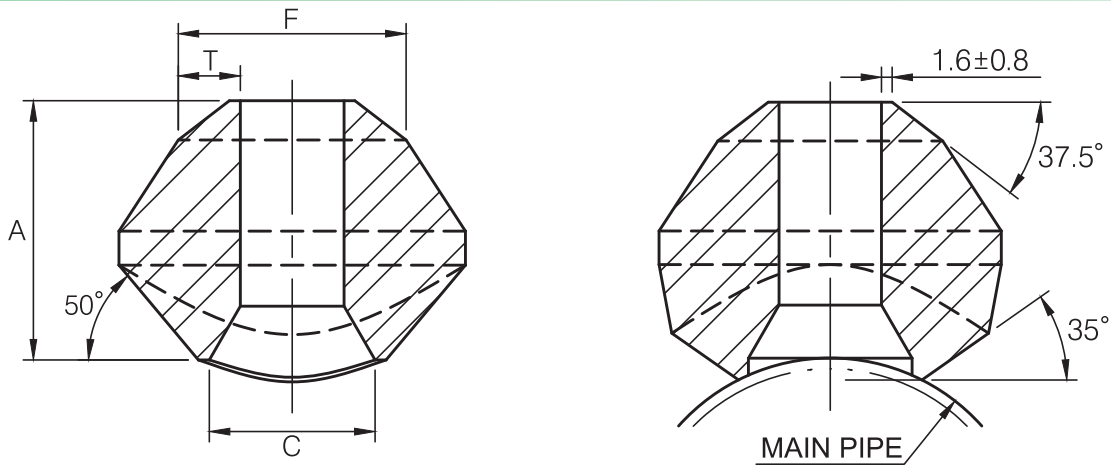

SCHEDULE 160 & DOUBLE EXTRA STRONG

Dimensions are in millimeters.

Reducing way					
OutLet Pipe (in)	A	C	F	T	
				S160	XXS
1/2	28.4	13.8	21.3	4.78	7.47
3/4	31.8	18.9	26.7	5.56	7.82
1	38.1	24.3	33.4	6.35	9.09
1-1/4	44.4	32.5	42.2	6.35	9.70
1-1/2	50.8	38.1	48.3	7.14	10.15
2	55.4	49.2	60.3	8.74	11.07
2-1/2	62.0	59.0	73.0	9.53	14.02
3	73.2	73.7	88.9	11.13	15.24
4	84.1	97.2	114.3	13.49	17.12
5	93.7	122.2	141.3	15.88	19.05
6	104.6	146.4	168.3	18.26	21.95

- (1) Weld bevel in accordance with ASME B16.25
- (2) Outlet size by order to specific size combination.

CONVENTIONAL RUN PIPE SIZE COMBINATIONS

3000lb THREAD/SOCKET-WELD END STD/XS BUTT WELDING END

		OUTLET SIZE										
		1/4"	3/8"	1/2"	3/4"	1"	1-1/4"	1-1/2"	2"	2-1/2"	3"	4"
RUN SIZE (MAIN PIPE)	Reducing way	3/8"~3/4" 1"~36"	1/2" 3/4"~1-1/4" 1-1/2"~36"	3/4" 1" 1-1/4" 1-1/2"~3" 3-1/2"~36"	1" 1-1/4" 1-1/2" 2"~3" 3-1/2"~6" 8"~36"	1-1/4" 1-1/2" 2" 2-1/2" 3"~4" 5"~10" 12"~36"	1-1/2" 2" 2-1/2" 3" 3-1/2"~5" 6"~8" 10"~36"	2" 2-1/2" 3" 3-1/2" 4"~5" 6"~10" 12"~36"	2-1/2" 3" 3-1/2" 4" 5"~6" 8"~10" 12"~18" 20"~36"	3" 3-1/2" 4" 5" 6" 8" 10"~14" 16"~36"	3-1/2" 4" 5" 6" 8" 10" 12"~16" 18"~36"	5" 6" 8" 10" 12"~14" 16"~18" 20"~24" 26"~36"
	Straight way	3/8"~36"	1/2"~36"	3/4"~36"	1"~36"	1-1/4"~1-1/2" 2"~36"	1-1/2" 2"~3" 3-1/2"~36"	2" 2-1/2"~4" 5"~36"	2-1/2" 3"~3-1/2" 4"~6" 8"~36"	3" 3-1/2"~4" 5"~8" 10"~36"	3-1/2" 4" 5" 6" 8"~12" 14"~36"	5" 6" 8" 10" 12"~16" 18"~36"

Each charted outlet size is designed to fit a number of run pipe sizes.



SOCKET WELDING 45° BRANCH OUTLET

MSS SP-97-2012

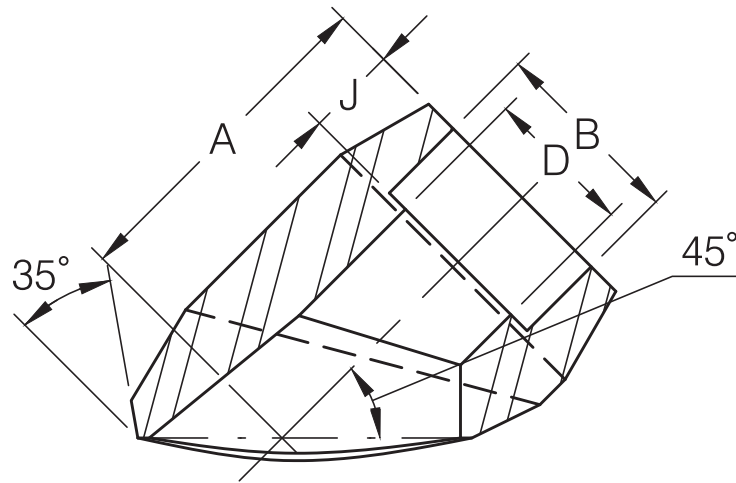

Dimensions are in millimeters.

45° Branch Outlet

Outlet Pipe		A		B ⁽³⁾	D ⁽³⁾	J (Min)
DN	IN	Min	Max			

3000Lb

8	1/4	38.1	42.9	14.2	9.3	9.5
10	3/8	38.1	42.9	17.6	12.6	9.5
15	1/2	38.1	44.5	21.8	15.8	9.5
20	3/4	46.0	50.8	27.2	21.0	12.5
25	1	54.0	63.5	33.9	26.7	12.5
32	1-1/4	61.1	76.2	42.7	35.1	12.5
40	1-1/2	63.5	76.2	48.8	40.9	12.5
50	2	76.2	84.1	61.2	52.5	16.0

6000Lb

8	1/4	38.9	47.6	14.2	6.4	9.5
10	3/8	38.9	47.6	17.6	9.2	9.5
15	1/2	46.0	55.6	21.8	11.8	9.5
20	3/4	54.0	63.5	27.2	15.6	12.5
25	1	61.1	73.0	33.9	20.7	12.5
32	1-1/4	65.1	77.8	42.7	29.5	12.5
40	1-1/2	78.6	85.7	48.8	34.0	12.5
50	2	78.6	104.8	61.2	42.9	16.0

(1) Socket weld in accordance with ASME B16.11

(2) Dimensions may vary in according to the customer and manufacturer requirements.

(3) Tolerance see page 20.



THREADED END 45° BRANCH OUTLET

MSS SP-97-2012

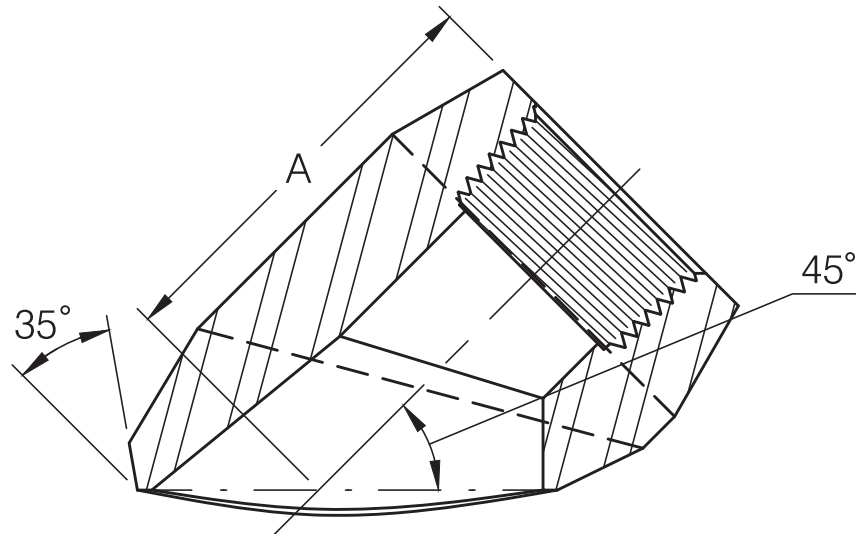

Dimensions are in millimeters.

45 Branch Outlet					
Outlet Pipe		A			
DN	IN	Min	Max	Min	Max
		3000Lb		6000Lb	
8	1/4	38.1	42.9	38.9	47.6
10	3/8	38.1	42.9	38.9	47.6
15	1/2	38.1	44.5	46.0	55.6
20	3/4	46.0	50.8	54.0	63.5
25	1	54.0	63.5	61.1	73.0
32	1-1/4	61.1	76.2	65.1	77.8
40	1-1/2	63.5	76.2	78.6	85.7
50	2	76.2	84.1	78.6	104.8

(1) Thread in accordance with ASME B1.20.1



BUTT WELDING END 45° BRANCH OUTLET

MSS SP-97-2012

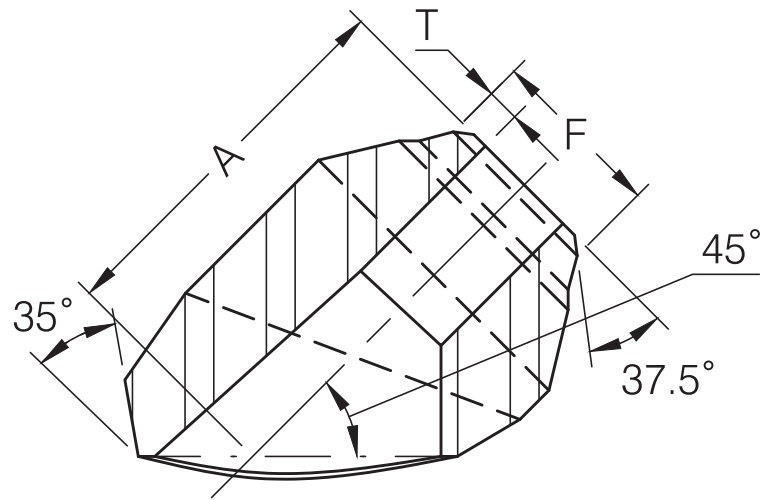

STANDARD WEIGHT & EXTRA STRONG

Dimensions are in millimeters.

45° Branch Outlet						
Outlet Pipe		A		T		F
DN	IN	Min	Max	Sch 40/STD	Sch 80/XS	
8	1/4	38.1	42.9	2.24	3.02	13.7
10	3/8	38.1	42.9	2.31	3.20	17.1
15	1/2	38.1	42.9	2.77	3.73	21.3
20	3/4	44.5	50.8	2.87	3.91	26.7
25	1	54.0	65.1	3.38	4.55	33.4
32	1-1/4	54.0	65.1	3.56	4.85	42.2
40	1-1/2	63.5	69.9	3.68	5.08	48.3
50	2	73.0	88.9	3.91	5.54	60.3

- (1) Weld bevel in accordance with ASME B16.25
- (2) Dimensions may vary in according to the customer and manufacturer requirements.
- (3) Wall thickness (T) in accordance with ASME B36.10M , ASME B36.19M , see page52 .



NIPPLE

ASTM A733-2015

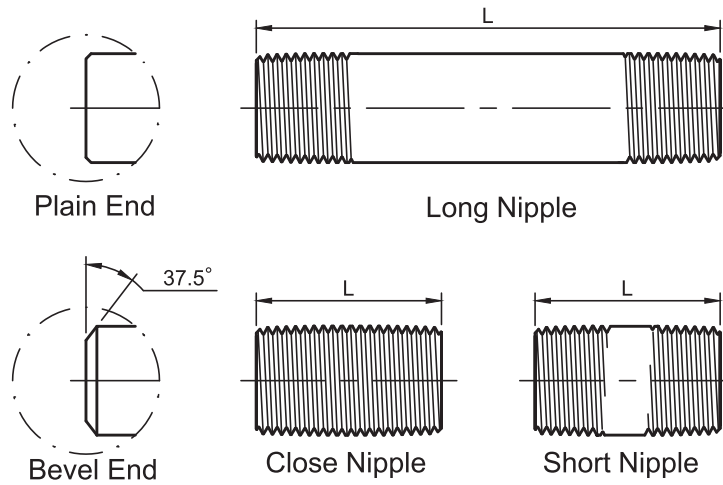

Dimensions in Inch.

Plain End Weight (Kg)per meter

Nom. Pipe Size	L			Weight			
	Close Nipple	Short Nipple	Long Nipple	Sch 40/STD	Sch 80/XS	Sch 160	XXS
1/8	3/4	1-1/2	2~12	0.37	0.47	-	-
1/4	7/8	1-1/2	2~12	0.63	0.80	-	-
3/8	1	1-1/2	2~12	0.84	1.10	-	-
1/2	1-1/8	1-1/2	2~12	1.27	1.62	1.95	2.55
3/4	1-3/8	1-1/2	2~12	1.69	2.20	2.90	3.64
1	1-1/2	2	2-1/2~12	2.50	3.24	4.24	5.45
1-1/4	1-5/8	2	2-1/2~12	3.39	4.47	5.61	7.77
1-1/2	1-3/4	2	2-1/2~12	4.05	5.41	7.25	9.56
2	2	2-1/2	3~12	5.44	7.48	11.11	13.44
2-1/2	2-1/2	3	3-1/2~12	8.63	11.41	14.92	20.39
3	2-5/8	3	3-1/2~12	11.29	15.27	21.35	27.68
3-1/2	2-3/4	4	4-1/2~12	13.57	18.64	-	-
4	2-7/8	4	4-1/2~12	16.07	22.32	33.54	41.03
5	3	4-1/2	5~12	21.77	30.97	49.12	57.43
6	3-1/8	4-1/2	5~12	28.26	42.56	67.56	79.22

- (1) Thread in accordance with ASME B1.20.1
- (2) Weld bevel in accordance with ASME B16.25
- (3) Weight: in accordance with ASME B36.10M.

Shape of Threaded

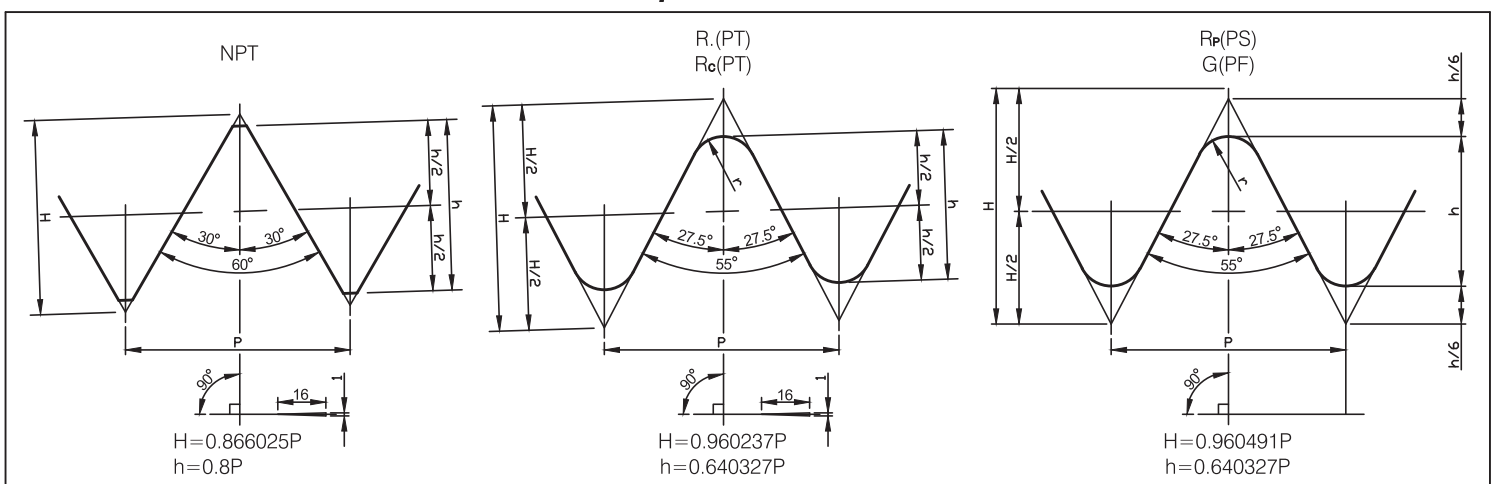



SPECIAL PRODUCT

SOCKET-WELDING 45° LATERAL TEE

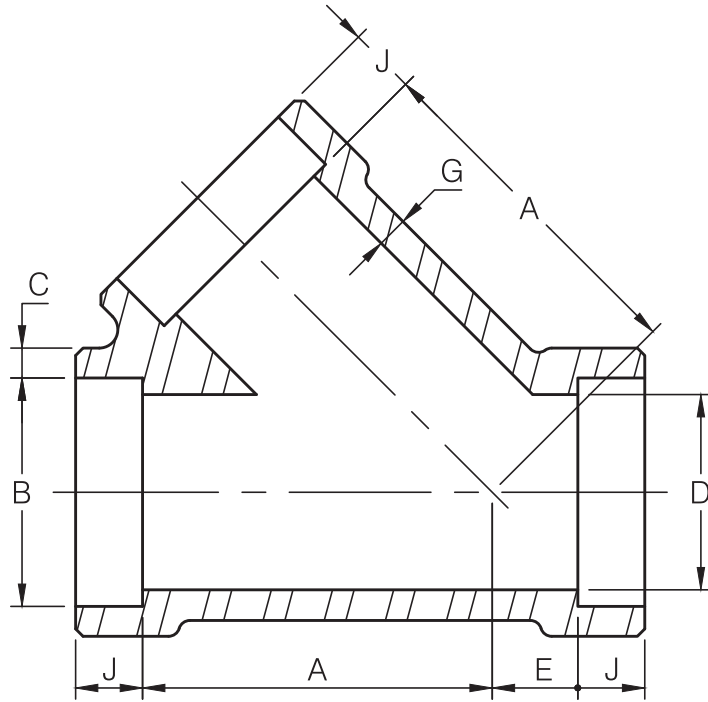

Dimensions are in millimeters.

Socket Welding									
DN	Nom. Pipe Size	B ⁽¹⁾	C ⁽¹⁾		D ⁽¹⁾	A	E	G ⁽¹⁾ (Min)	J ⁽¹⁾ (Min)
			(Avg)	(Min)					

3000Lb

15	1/2	21.8	4.67	4.09	15.8	35	9	3.75	9.5
20	3/4	27.2	4.90	4.27	21.0	41	9	3.95	12.5
25	1	33.9	5.69	4.98	26.7	51	12	4.55	12.5
32	1-1/4	42.7	6.07	5.28	35.1	59	17	4.85	12.5
40	1-1/2	48.8	6.35	5.54	40.9	68	21	5.10	12.5
50	2	61.2	6.93	6.04	52.5	95	24	5.55	16.0
65	2-1/2	73.9	8.76	7.67	62.7	118	38	7.05	16.0

6000Lb

15	1/2	21.8	5.97	5.18	11.8	41	9	4.78	9.5
20	3/4	27.2	6.96	6.04	15.6	51	12	5.56	12.5
25	1	33.9	7.92	6.93	20.7	59	17	6.35	12.5
32	1-1/4	42.7	7.92	6.93	29.5	68	21	6.35	12.5
40	1-1/2	48.8	8.92	7.80	34.0	95	24	7.14	12.5
50	2	61.2	10.92	9.50	42.9	106	31	8.74	16.0

(1) Dimensions refer to ANSI B16.11 for class 3M, socket welding fittings.

(2) Dimensions may vary in according to the customer and manufacturer requirements.



SPECIAL PRODUCT

THREADED 45° LATERAL TEE

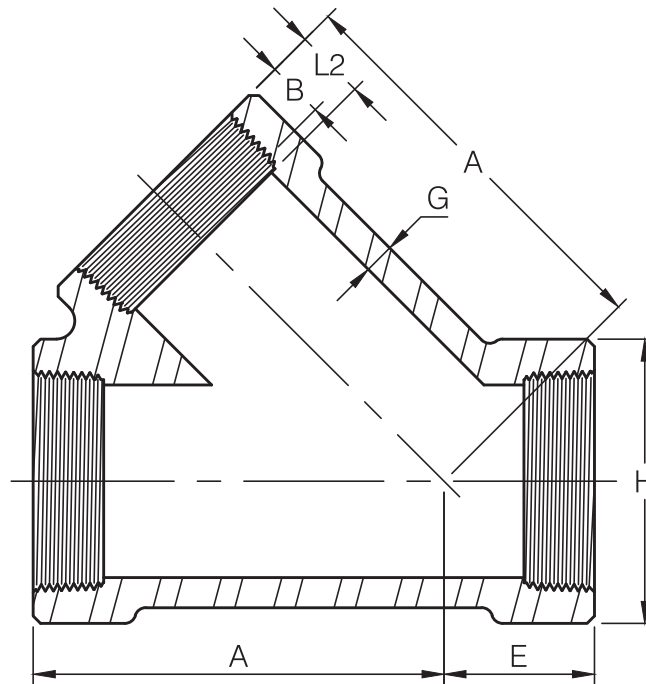

Dimensions are in millimeters.

Threaded							
DN	Nom. Pipe Size	Length of Thread (Min)		A	E	G ⁽¹⁾ (Min)	H ⁽¹⁾
		B ⁽²⁾	L2 ⁽²⁾				

2000Lb

15	1/2	10.9	13.6	46	20	3.18	33
20	3/4	12.7	13.9	55	23	3.18	38
25	1	14.7	17.3	65	26	3.68	46
32	1-1/4	17.0	18.0	73	31	3.89	56
40	1-1/2	17.8	18.4	82	35	4.01	62
50	2	19.0	19.2	113	42	4.27	75
65	2-1/2	23.6	28.9	136	56	5.61	92

3000Lb

15	1/2	10.9	13.6	55	23	4.09	38
20	3/4	12.7	13.9	65	26	4.32	46
25	1	14.7	17.3	73	31	4.98	56
32	1-1/4	17.0	18.0	82	35	5.28	62
40	1-1/2	17.8	18.4	113	42	5.56	75
50	2	19.0	19.2	136	56	7.14	84

(1) Dimensions refer to ANSI B16.11, forged threaded fittings.

(2) Dimension B is minimum length of perfect thread.

The length of useful thread (B plus threads with fully formed roots and flat crests) shall not be less than L2 (effective length of external thread) required by American National Standard for pipe threads (ANSI/ASME B1.20.1).

(3) Dimensions of BSP and PT are available if required.

(4) Dimensions may vary in according to the customer and manufacturer requirements.



SPECIAL PRODUCT

SOCKET WELDING END 90° ELBOW OUTLET

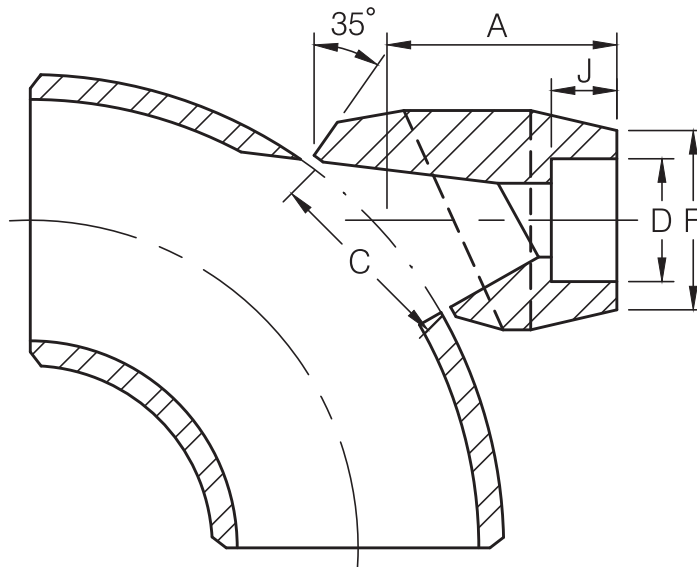

Dimensions are in millimeters.

90° ELBOW OUTLET						
Outlet Pipe		A	C	F	D	J
DN	IN					

3000Lb (XS)

8	1/4	40.5	35.2	22.0	14.35	10.0
10	3/8	40.5	35.2	25.9	17.80	10.0
15	1/2	40.5	35.2	31.4	21.95	11.1
20	3/4	47.6	43.6	37.1	27.30	12.7
25	1	55.6	54.0	45.5	34.05	13.5
32	1-1/4	60.3	67.5	57.0	42.80	15.1
40	1-1/2	66.7	76.2	64.0	48.90	15.9
50	2	81.0	104.8	76.0	61.35	17.5
65	2-1/2	82.6	106.4	92.0	74.15	23.8
80	3	96.8	125.4	109.2	90.10	28.6
100	4	114.3	163.5	140.0	115.75	29.4

6000Lb (Sch160)

8	1/4	40.5	35.2	26.0	14.35	10.0
10	3/8	40.5	35.2	33.0	17.80	10.0
15	1/2	47.6	35.2	38.0	21.95	10.0
20	3/4	55.6	43.6	44.0	27.30	14.3
25	1	60.3	54.0	57.0	34.05	15.9
32	1-1/4	66.7	67.5	64.0	42.80	20.6
40	1-1/2	85.7	76.2	76.0	48.90	20.6

- (1) Socket weld in accordance with ASME B16.11
- (2) Dimensions may vary in according to the customer and manufacturer requirements.



SPECIAL PRODUCT

THREADED END 90° ELBOW OUTLET

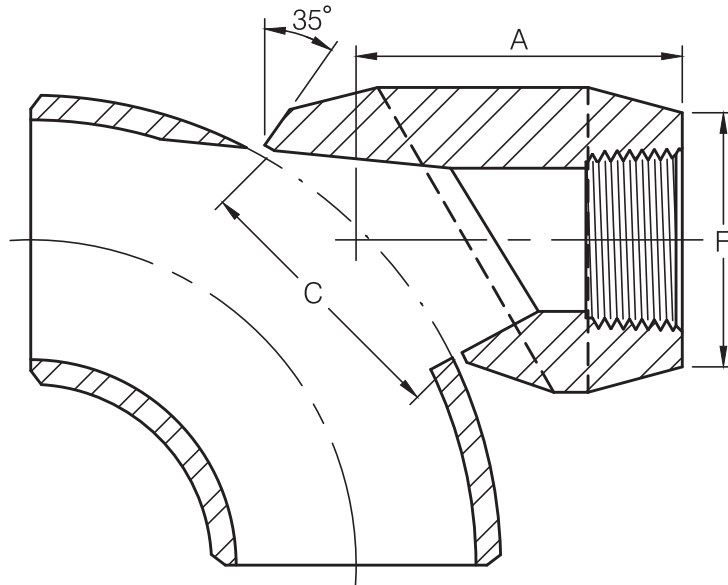

Dimensions are in millimeters.

90° ELBOW OUTLET				
Outlet Pipe		A	C	F
DN	IN			
3000Lb (XS)				
8	1/4	40.5	35.2	22.0
10	3/8	40.5	35.2	25.9
15	1/2	40.5	35.2	31.4
20	3/4	47.6	43.6	37.1
25	1	55.6	54.0	45.5
32	1-1/4	60.3	67.5	57.0
40	1-1/2	66.7	76.2	64.0
50	2	81.0	104.8	76.0
65	2-1/2	82.6	106.4	92.0
80	3	96.8	125.4	109.2
100	4	114.3	163.5	140.0
6000Lb (Sch160)				
8	1/4	40.5	35.2	26.0
10	3/8	40.5	35.2	33.0
15	1/2	47.6	35.2	38.0
20	3/4	55.6	43.6	44.0
25	1	60.3	54.0	57.0
32	1-1/4	66.7	67.5	64.0
40	1-1/2	85.7	76.2	76.0

(1) Thread in accordance with ASME B1.20.1

(2) Dimensions may vary in according to the customer and manufacturer requirements.



SPECIAL PRODUCT

BUTT WELDING END 90° ELBOW OUTLET

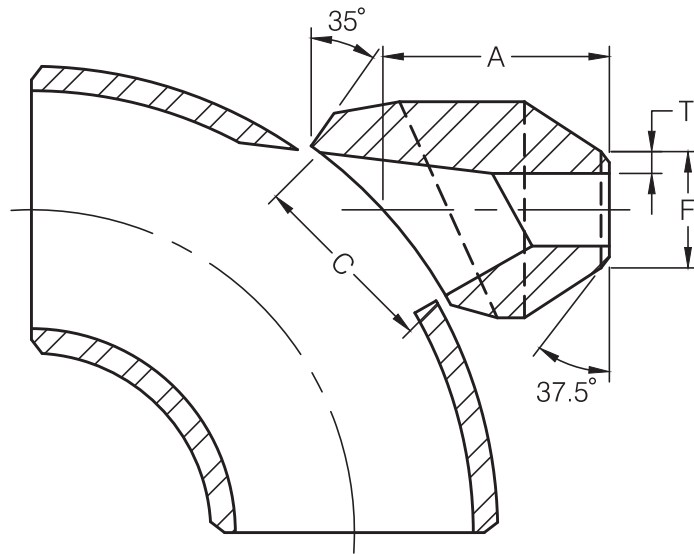

Dimensions are in millimeters.

90° ELBOW OUTLET					
Outlet Pipe		A	C	F	T
DN	IN				

Sch 80

8	1/4	40.5	35.2	13.7	3.0
10	3/8	40.5	35.2	17.1	3.2
15	1/2	40.5	35.2	21.3	3.7
20	3/4	47.6	43.6	26.7	3.9
25	1	55.6	54.0	33.4	4.5
32	1-1/4	60.3	67.5	42.2	4.9
40	1-1/2	66.7	76.2	48.3	5.1
50	2	81.0	104.8	60.3	5.5
65	2-1/2	82.6	106.4	73.0	7.0
80	3	96.8	125.4	88.9	7.6
100	4	114.3	163.5	114.3	8.6

Sch 160

8	1/4	40.5	35.2	13.7	3.7
10	3/8	40.5	35.2	17.1	4.0
15	1/2	47.6	35.2	21.3	4.7
20	3/4	55.6	43.6	26.7	5.5
25	1	60.3	54.0	33.4	6.4
32	1-1/4	66.7	67.5	42.2	6.4
40	1-1/2	85.7	76.2	48.3	7.1

(1) Weld bevel in accordance with ASME B16.25

(2) Dimensions may vary in according to the customer and manufacturer requirements.



SPECIAL PRODUCT

NIPPLE BRANCH OUTLET

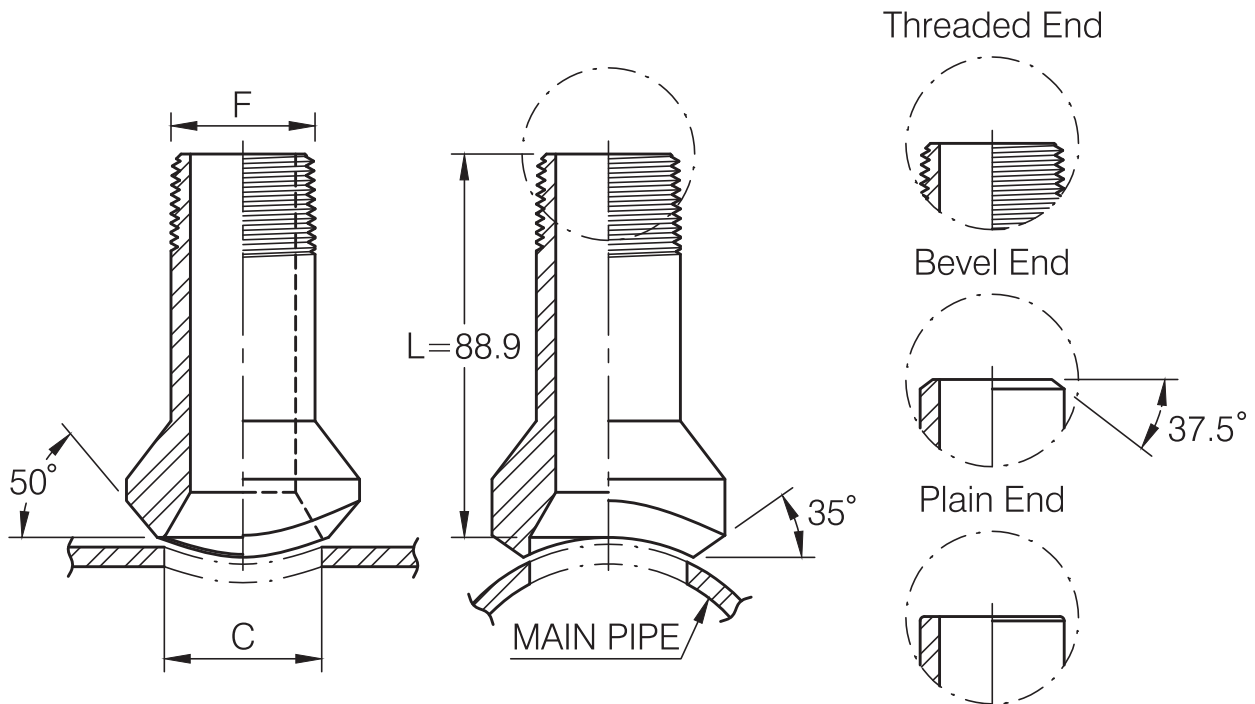

Dimensions are in millimeters.

Outlet Pipe(in)	C	F
-----------------	---	---

3000Lb (XS)

1/2	23.8	21.3
3/4	30.2	26.7
1	36.5	33.4
1-1/4	44.5	42.2
1-1/2	50.8	48.3
2	65.1	60.3

6000Lb (Sch 160)

1/2	13.8	21.3
3/4	18.9	26.7
1	24.3	33.4
1-1/4	32.5	42.2
1-1/2	38.1	48.3
2	49.2	60.3

(1) The end of the fitting can be :

- Plain.
- Weld bevel in accordance with ASME B16.25 .
- Thread in accordance with ASME B1.20.1 .

(2) Range :

- Thread : Class 3000 / 6000 Lb .
- Plain and weld : Sch40 / STD / Sch80 / XS / Sch160 / XXS .

(3) Dimensions may vary in according to the customer and manufacturer requirements.



SPECIAL PRODUCT

THREADED ADAPTER

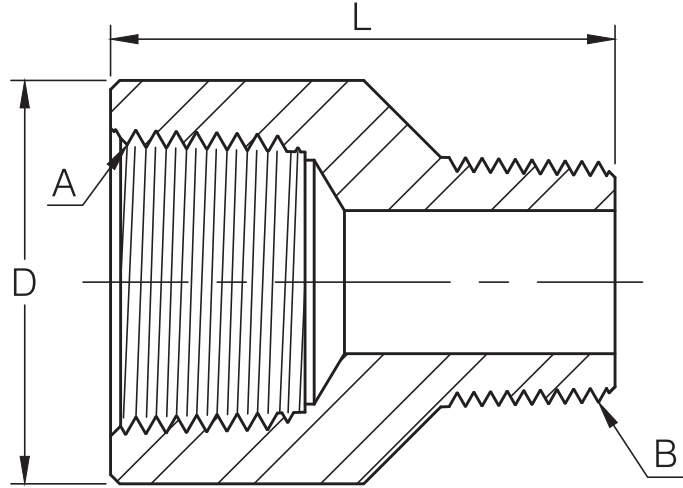

Dimensions are in millimeters.

DN	Nom Pipe Size (A)	D	L	Threaded Size (B)
----	-------------------	---	---	-------------------

3000Lb

8	1/4	19	33	1/8
10	3/8	22	35	1/4
15	1/2	28	42	3/8
20	3/4	35	47	1/2
25	1	44	55	3/4
32	1-1/4	57	63	1
40	1-1/2	64	66	1-1/4
50	2	76	76	1-1/2
65	2-1/2	92	90	2
80	3	108	110	2-1/2
100	4	140	120	3

(1) Thread in accordance with ANSI / ASME B 1.20.1.

(2) Dimensions may vary in according to the customer and manufacturer requirements.



SPECIAL PRODUCT

UNION (M/F)

H-Thrd's
 Minimum 4 Full Thrd's
 Engagement Class 2A/2B Fit
 ANSI B1.1

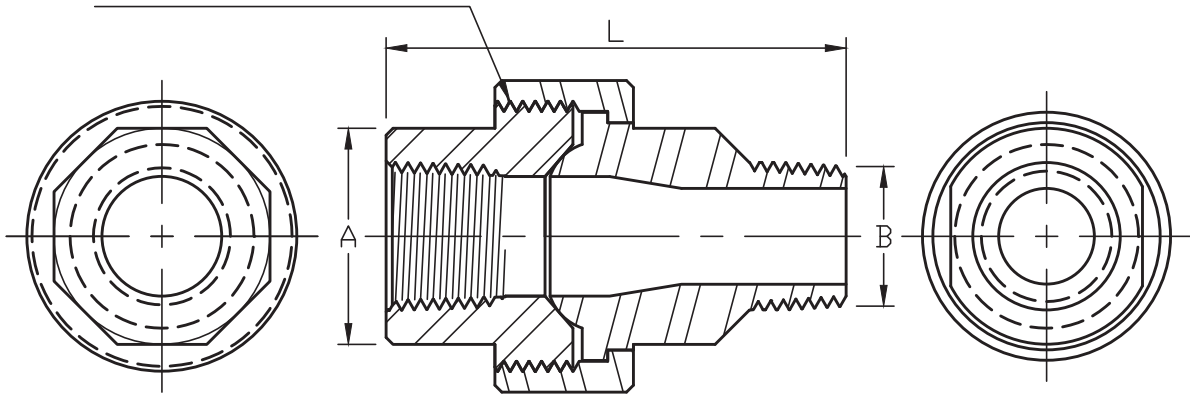

TYPE 1

Dimensions are in millimeters.

Nom Pipe Size	A ⁽¹⁾ (Min)	B	L
3000Lb			
1/4	19.0	13.7	55.4
3/8	22.9	17.1	60.0
1/2	27.7	21.3	68.0
3/4	33.5	26.7	75.9
1	41.4	33.4	86.0
1-1/4	50.5	42.2	95.1
1-1/2	57.2	48.3	100.5
2	70.1	60.3	112.1

(1) Dimensions refer to MSS SP-83

(2) Thread in accordance with ANSI/ASME B 1.20.1

(3) Dimensions may vary in according to the customer and manufacturer requirements.



SPECIAL PRODUCT

UNION (M/F)

H-Thrd's
 Minimum 4 Full Thrd's
 Engagement Class 2A/2B Fit
 ANSI B1.1

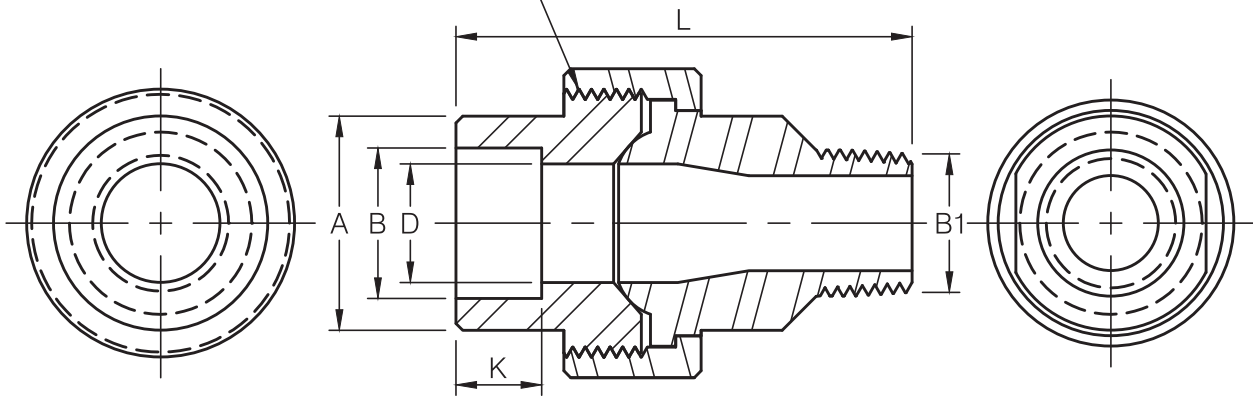

TYPE 2

Dimensions are in millimeters.

Nom Pipe Size	A ⁽¹⁾ (Min)	B1	B	D	K (Min)	L
3000Lb						
1/4	21.8	13.7	14.61 14.10	10.01 8.48	9.7	55.4
3/8	25.9	17.1	18.03 17.53	13.28 11.76	9.7	60.0
1/2	31.2	21.3	22.23 21.72	16.56 15.04	9.7	68.0
3/4	37.1	26.7	27.56 27.05	21.69 20.17	12.7	75.9
1	45.5	33.4	34.29 33.78	27.41 25.88	12.7	86.0
1-1/4	54.9	42.2	43.05 42.55	35.81 34.29	12.7	95.1
1-1/2	61.5	48.3	49.15 48.64	41.66 40.13	12.7	100.5
2	75.2	60.3	61.62 61.11	53.26 51.74	15.7	112.1

(1) Dimensions refer to MSS SP-83

(2) Thread/Socket weld in accordance with ANSI/ASME B 16.11 and ANSI/ASME B 1.20.1

(3) Dimensions may vary in according to the customer and manufacturer requirements.



DIMENSIONS OF SEAMLESS STEEL PIPE AND SEAMLESS STAINLESS STEEL PIPE

(ASME B36.10M-2004 , ASME B36.19M-2004)

Unit : mm

TOLERANCES			STEEL PIPE																	STAINLESS STEEL PIPE						
			Outside Dia.			SCHEDULE NUMBER(SCH) AND WALL THICKNESS														5S	10S	40S	80S			
A53 A106 O.D.	API 5L O.D.	A530 O.D.	NPS IN	STD	MAX	MIN	10	20	30	40	STD	60	XS	80	100	120	140	160	XXS	5S	10S	40S	80S			
+1/64" -1/32"	+1/64" -1/32"	+1/64" -1/32"	1/8	10.3	10.7	9.5	1.24	-	1.45	1.73	1.73	-	2.41	2.41	-	-	-	*3.15	*4.83	1.7	1.2	1.7	2.4			
			1/4	13.7	14.1	12.9	1.65	-	1.85	2.24	2.24	-	3.02	3.02	-	-	-	-	*3.68	*6.05	1.7	1.7	2.2	3.0		
			3/8	17.1	17.5	16.3	1.65	-	1.85	2.31	2.31	-	3.20	3.20	-	-	-	-	-	*4.01	*6.40	1.7	1.7	2.3	3.2	
			1/2	21.3	21.7	20.5	2.11	-	2.41	2.77	2.77	-	3.73	3.73	-	-	-	-	-	-	4.78	7.47	1.7	2.1	2.8	3.7
			3/4	26.7	27.1	25.9	2.11	-	2.41	2.87	2.87	-	3.91	3.91	-	-	-	-	-	-	5.56	7.82	1.7	2.1	2.9	3.9
			1	33.4	33.8	32.8	2.77	-	2.97	3.38	3.38	-	4.55	4.55	-	-	-	-	-	-	6.35	9.09	1.7	2.8	3.4	4.5
			1-1/4	42.2	42.6	41.4	2.77	-	2.97	3.56	3.56	-	4.85	4.85	-	-	-	-	-	-	6.35	9.70	2.1	2.8	3.6	4.9
			1-1/2	48.3	48.7	47.5	2.77	-	3.18	3.68	3.68	-	5.08	5.08	-	-	-	-	-	-	7.14	10.15	2.1	2.8	3.7	5.1
			2	60.3	60.9	59.7	2.77	-	3.18	3.91	3.91	-	5.54	5.54	-	-	-	-	-	-	8.74	11.07	2.1	2.8	3.9	5.5
			2-1/2	73.0	73.7	72.2	3.05	-	4.78	5.16	5.16	-	7.01	7.01	-	-	-	-	-	-	9.53	14.02	2.1	3.0	5.2	7.0
±1%	±0.75%	+1/16" -1/32"	3	88.9	89.8	88.0	3.05	-	4.78	5.49	5.49	-	7.62	7.62	-	-	-	-	11.13	15.24	2.8	3.0	5.5	7.6		
			3-1/2	101.6	102.6	100.6	3.05	-	4.78	5.74	5.74	-	8.08	8.08	-	-	-	-	-	-	-	2.8	3.0	5.7	8.1	
			4	114.3	115.4	113.2	3.05	-	4.78	6.02	6.02	-	8.56	8.56	-	-	-	-	-	13.49	17.12	2.8	3.0	6.0	8.6	
			5	141.3	142.7	139.9	3.40	-	-	6.55	6.55	-	9.53	9.53	-	-	-	-	-	-	15.88	19.05	3.4	3.4	6.6	9.5
			6	168.3	170.0	166.6	3.40	-	-	7.11	7.11	-	10.97	10.97	-	-	-	-	-	-	18.26	21.95	4.0	3.4	7.1	11.0
			8	219.1	221.3	216.9	3.76	6.35	7.04	8.18	8.18	-	12.70	12.70	10.31	12.70	12.70	15.09	18.26	20.62	23.01	22.23	4.0	3.8	8.2	12.7
			10	273.0	275.8	270.4	4.19	6.35	7.80	9.27	9.27	-	12.70	12.70	12.70	12.70	15.09	18.26	21.44	25.40	28.58	25.40	4.2	4.2	9.3	12.7
			12	323.8	327.1	320.7	4.57	6.35	8.38	10.31	9.53	-	14.27	12.70	14.27	12.70	17.48	21.44	25.40	28.58	33.32	25.40	4.2	4.6	9.5	12.7
			14	355.6	359.2	352.0	6.35	7.92	9.53	11.13	9.53	-	15.09	12.70	15.09	12.70	19.05	23.83	27.79	31.75	35.71	-	4.8	-	-	-
			16	406.4	410.5	402.3	6.35	7.92	9.53	12.70	9.53	-	16.66	12.70	16.66	12.70	21.44	26.19	30.96	36.53	40.49	-	4.8	-	-	-
+0.15% -0.25%	+1/8" -1/32"	+1/8" -1/32"	18	457.0	461.8	452.6	6.35	7.92	11.13	14.27	9.53	-	19.05	12.70	23.83	29.36	34.93	39.67	45.24	-	5.5	6.4	-	-		
			20	508.0	513.1	502.9	6.35	9.53	12.70	15.09	9.53	-	20.62	12.70	26.19	32.54	38.10	44.45	50.01	-	-	-	-	-		
			22	559.0	-	-	6.35	9.53	12.70	-	9.53	-	22.23	12.70	28.58	34.93	41.28	47.63	53.98	-	-	-	-	-		
			24	610.0	615.7	603.5	6.35	9.53	14.27	17.48	9.53	-	24.61	12.70	30.96	38.89	46.02	52.37	59.54	-	6.4	7.9	-	-	-	
			26	660.0	-	-	7.92	12.70	-	-	9.53	-	26.19	-	12.70	-	-	-	-	-	-	-	-	-	-	-
			28	711.0	-	-	7.92	12.70	15.88	-	9.53	-	28.58	-	12.70	-	-	-	-	-	-	-	-	-	-	-
			30	762.0	-	-	7.92	12.70	15.88	-	9.53	-	30.96	-	12.70	-	-	-	-	-	-	-	-	-	-	-
			32	813.0	-	-	7.92	12.70	15.88	17.48	9.53	-	32.54	-	12.70	-	-	-	-	-	-	-	-	-	-	-
			34	864.0	-	-	7.92	12.70	15.88	17.48	9.53	-	34.93	-	12.70	-	-	-	-	-	-	-	-	-	-	-
			36	914.0	-	-	7.92	12.70	15.88	19.05	9.53	-	38.89	-	12.70	-	-	-	-	-	-	-	-	-	-	-

* Thickness in accordance with ASME B16.11.



PACKING LIST

Carton Size : 28 x 20 x 18 cm (L x W x H)

Unit : PC

SIZE NPS	90° Elbow				45° Elbow				Tee				
	2M NPT 3M SW	3M NPT	6M SW	6M NPT	2M NPT 3M SW	3M NPT	6M SW	6M NPT	2M NPT 3M SW	3M NPT	6M SW	6M NPT	9M SW
1/4"	150	100	100	80	150	100	100	80	100	80	80	50	50
3/8"	100	80	80	50	100	80	80	50	80	50	50	35	35
1/2"	80	50	50	25	80	50	50	25	50	35	35	20	15
3/4"	50	25	25	20	50	30	30	20	35	20	20	12	15
1"	30	20	20	12	30	20	20	12	20	15	15	10	10
1-1/4"	20	15	15	5	20	15	15	5	15	10	10	5	6
1-1/2"	15	6	6	4	15	8	8	4	10	5	5	4	4
2"	8	5	5	2	10	6	6	2	6	4	4	2	2
2-1/2"	4	2	2	1	5	2	2	1	3	2	2	1	-
3"	2	2	1	1	2	2	1	1	2	1	1	1	-
4"	1	1	1	1	1	1	1	1	1	1	1	1	-

SIZE NPS	Cross				Full Coupling				Half Coupling			
	2M NPT 3M SW	3M NPT	6M SW	6M NPT	3M SW	3M NPT	6M SW	6M NPT	3M SW	3M NPT	6M SW	6M NPT
1/4"	40	40	80	40	350	250	250	200	400	800	300	150
3/8"	40	40	40	30	250	200	200	100	250	500	150	80
1/2"	40	30	30	20	120	100	100	60	120	250	80	80
3/4"	30	20	20	12	80	70	70	35	80	150	50	50
1"	20	12	12	6	50	35	35	20	50	80	30	35
1-1/4"	10	6	6	4	30	20	20	15	30	35	25	25
1-1/2"	6	4	4	2	25	15	15	10	25	30	15	20
2"	4	4	2	1	15	10	10	5	15	20	10	6
2-1/2"	2	1	-	-	10	5	5	3	10	12	5	4
3"	1	1	-	-	6	3	3	2	6	6	3	2
4"	-	-	-	-	4	2	2	1	4	4	-	1

SIZE NPS	Cap			Boss				Street Elbow		Insert	
	3M SW/NPT	6M SW	6M NPT	3M SW	3M NPT	6M SW	6M NPT	3M NPT	6M NPT	3M SW	6M SW
1/4"	300	200	250	250	200	200	150	150	80	300	250
3/8"	250	150	130	200	150	150	100	80	50	300	200
1/2"	130	80	80	90	80	80	60	50	25	150	120
3/4"	80	50	50	70	40	40	35	30	20	100	80
1"	50	30	30	35	30	30	20	20	12	80	60
1-1/4"	30	25	25	30	20	20	15	15	5	60	50
1-1/2"	25	15	15	25	15	15	10	8	4	40	40
2"	15	8	10	15	10	10	5	5	2	25	20
2-1/2"	10	5	4	10	5	-	-	4	-	12	10
3"	4	3	3	6	3	-	-	2	-	10	8
4"	3	2	2	4	2	-	-	1	-	4	2

SIZE NPS	OutLet		Union		Hex Plug	Round Plug	Square Plug	Bushing	Hex Nipple	Swage Nipple
	3M SW/NPT	6M SW/NPT	3M SW/NPT	6M SW/NPT	NPT	NPT	NPT	NPT	NPT	S40/S80 S160/XXS
1/4"	200	100	70	50	800	250	800	600	500	200
3/8"	150	100	70	50	600	200	500	500	400	150
1/2"	150	100	50	30	250	150	300	400	200	100
3/4"	100	50	30	20	150	100	200	200	100	70
1"	50	30	20	14	100	80	150	100	65	50
1-1/4"	35	25	14	10	35	50	80	60	35	30
1-1/2"	25	15	10	6	25	30	50	50	25	20
2"	15	10	6	2	20	15	30	25	15	8
2-1/2"	10	5	2	-	8	10	15	15	5	4
3"	6	2	2	-	6	5	10	10	3	3
4"	3	1	1	-	3	3	3	5	2	1

PLYWOOD CASE SIZE : 109x94x86cm / 60 CARTON
 PLYWOOD CASE SIZE : 93x90x86cm / 48 CARTON
 PLYWOOD CASE SIZE : 93x90x68cm / 36 CARTON



WEIGHT LIST

Unit : Kg

SIZE NPS	90° Elbow					45° Elbow					Tee				
	2M NPT	3M SW	3M NPT	6M SW	6M NPT	2M NPT	3M SW	3M NPT	6M SW	6M NPT	2M NPT	3M SW	3M NPT	6M SW	6M NPT
1/8"	0.10	0.09	0.10	0.10	0.17	0.09	0.08	0.09	0.09	0.11	0.13	0.13	0.13	0.14	0.20
1/4"	0.08	0.08	0.14	0.15	0.33	0.08	0.07	0.12	0.14	0.27	0.12	0.09	0.20	0.20	0.45
3/8"	0.13	0.12	0.29	0.29	0.45	0.10	0.11	0.24	0.26	0.39	0.17	0.15	0.38	0.43	0.63
1/2"	0.25	0.22	0.43	0.40	0.80	0.20	0.20	0.34	0.36	0.63	0.31	0.29	0.56	0.56	0.98
3/4"	0.35	0.33	0.69	0.73	1.31	0.27	0.28	0.56	0.57	1.07	0.43	0.42	0.92	0.94	1.65
1"	0.53	0.53	1.14	1.17	1.61	0.41	0.42	0.94	0.92	1.27	0.69	0.65	1.49	1.49	2.17
1-1/4"	0.82	0.84	1.42	1.48	2.93	0.68	0.69	1.03	1.11	2.24	1.07	1.04	1.76	1.93	3.74
1-1/2"	1.06	1.08	2.63	2.79	3.79	0.82	0.80	2.05	2.01	2.54	1.39	1.35	3.27	3.37	4.71
2"	1.70	1.68	2.92	3.28	7.31	1.41	1.35	2.23	2.09	4.37	2.16	2.04	3.53	3.95	7.88
2-1/2"	3.58	3.20	5.99	-	9.88	2.60	2.53	3.71	-	7.01	4.11	3.98	6.99	-	13.11
3"	4.81	5.38	8.88	-	17.73	4.23	5.10	5.97	-	14.16	6.12	5.90	10.19	-	21.70
4"	10.21	10.95	14.85	-	15.76	8.96	9.41	8.96	-	11.36	14.74	13.92	19.13	-	18.53

SIZE NPS	Cross				Full Coupling				Half Coupling			
	2M NPT	3M SW	3M NPT	6M SW	3M SW	3M NPT	6M SW	6M NPT	3M SW	3M NPT	6M SW	6M NPT
1/8"	0.17	0.16	0.17	0.17	0.04	0.05	0.05	0.08	0.04	0.02	0.06	0.07
1/4"	0.14	0.13	0.26	0.26	0.05	0.04	0.07	0.13	0.05	0.02	0.09	0.06
3/8"	0.21	0.20	0.44	0.45	0.07	0.06	0.11	0.20	0.07	0.03	0.12	0.09
1/2"	0.39	0.35	0.72	0.67	0.13	0.13	0.20	0.34	0.13	0.06	0.21	0.16
3/4"	0.54	0.47	1.06	1.07	0.17	0.19	0.27	0.50	0.21	0.10	0.31	0.24
1"	0.83	0.73	1.79	1.75	0.29	0.45	0.44	0.87	0.30	0.23	0.51	0.45
1-1/4"	1.26	1.12	2.13	2.26	0.45	0.81	0.60	1.09	0.34	0.34	0.75	0.55
1-1/2"	1.75	1.58	3.93	3.96	0.59	1.07	1.11	1.94	0.66	0.54	1.25	0.96
2"	2.65	2.25	4.27	4.42	0.86	1.40	1.62	2.87	1.09	0.70	1.92	1.70
2-1/2"	5.26	4.37	8.51	-	1.40	2.29	-	4.20	1.63	1.13	-	2.10
3"	7.58	6.69	12.45	-	1.78	3.38	-	6.10	2.10	1.68	-	3.05
4"	16.35	14.58	21.93	-	2.85	6.28	-	10.04	3.71	3.11	-	5.02

SIZE NPS	Reducing Coupling				Cap				Union				Street Elbow	Hex Nipples	Square Head Plug
	3M SW	3M NPT	6M SW	6M NPT	3M SW	3M NPT	6M SW	6M NPT	3M SW	3M NPT	6M SW	6M NPT	3M NPT	3M NPT	
1/8"	0.04	0.05	-	0.08	0.03	0.02	0.05	0.06	0.28	0.28	-	-	0.13	0.03	0.01
1/4"	0.05	0.05	-	0.06	0.04	0.04	0.08	0.06	0.28	0.28	-	-	0.11	0.04	0.01
3/8"	0.07	0.06	-	0.18	0.07	0.05	0.10	0.09	0.25	0.24	0.38	0.38	0.22	0.05	0.03
1/2"	0.13	0.13	0.24	0.31	0.10	0.11	0.16	0.26	0.35	0.34	0.61	0.56	0.31	0.09	0.05
3/4"	0.19	0.19	0.33	0.41	0.16	0.18	0.23	0.40	0.49	0.48	0.92	0.83	0.53	0.15	0.09
1"	0.27	0.39	0.65	0.85	0.25	0.37	0.36	0.71	0.81	0.77	1.44	1.29	1.02	0.47	0.16
1-1/4"	0.49	0.68	0.75	1.05	0.45	0.62	0.64	0.90	1.10	1.03	1.81	1.64	1.13	0.45	0.27
1-1/2"	0.59	0.99	1.20	1.81	0.59	0.72	0.94	1.28	1.61	1.63	3.12	2.85	2.01	0.62	0.38
2"	0.97	1.37	2.12	3.40	0.96	1.09	1.41	2.23	2.16	2.43	5.20	4.70	2.91	1.03	0.63
2-1/2"	1.42	2.07	-	4.20	1.43	2.22	-	3.68	3.50	3.63	-	-	-	1.51	0.96
3"	1.88	3.08	-	6.10	2.74	3.50	-	5.12	5.15	5.27	-	-	-	2.22	1.53
4"	3.31	5.44	-	10.04	4.24	4.84	-	8.60	11.59	12.00	-	-	-	4.00	3.83

SIZE NPS	Hex Head Plug	Round Head Plug	Bushing	Reducing inserts											
				SIZE	3M	6M	SIZE	3M	6M	SIZE	3M	6M	SIZE	3M	6M
1/8"	0.01	0.02	-	3/8X1/4	0.05	0.06	1-1/4X1/2	0.29	0.34	2X1/2	0.79	0.87	4X2-1/2	3.23	-
1/4"	0.03	0.05	0.01	1/2X3/8	0.07	0.09	1-1/4X3/8	0.32	0.36	2-1/2X2	1.02	1.43	4X2	3.74	-
3/8"	0.05	0.07	0.01	1/2X1/4	0.07	0.08	1-1/4X1/4	0.34	0.37	2-1/2X1-1/2	1.15	1.26	4X1-1/2	4.20	-
1/2"	0.07	0.12	0.03	3/4X1/2	0.11	0.15	1-1/2X1-1/4	0.34	0.53	2-1/2X1-1/4	1.32	1.38	4X1-1/4	4.39	-
3/4"	0.14	0.20	0.05	3/4X3/8	0.08	0.12	1-1/2X1	0.30	0.47	2-1/2X1	1.51	1.56			
1"	0.22	0.34	0.09	3/4X1/4	0.10	0.13	1-1/2X3/4	0.37	0.48	2-1/2X3/4	1.62	1.65			
1-1/4"	0.44	0.55	0.25	1X3/4	0.17	0.25	1-1/2X1/2	0.42	0.52	3X2-1/2	1.38	2.41			
1-1/2"	0.59	0.79	0.34	1X1/2	0.13	0.22	1-1/2X3/8	0.45	0.55	3X2	1.40	1.76			
2"	1.03	1.47	0.45	1X3/8	0.16	0.21	2X1-1/2	0.56	0.87	3X1-1/2	1.78	2.08			
2-1/2"	1.80	2.34	0.60	1X1/4	0.19	0.22	2X1-1/4	0.51	0.61	3X1-1/4	1.93	2.21			
3"	2.60	3.26	1.16	1-1/4X1	0.26	0.40	2X1	0.65	0.75	3X1	2.11	2.39			
4"	5.20	6.24	3.20	1-1/4X3/4	0.25	0.30	2X3/4	0.73	0.83	4X3	2.29	-			

生產製造：
鍛造碳鋼、不鏽鋼、合金鋼
絲口、套焊高壓鋼管配件



柏緯鐵工股份有限公司

公司.仁武廠：高雄市仁武區烏林里仁心路303號(81460)

電話：(07)371-1536. 371-0497. 372-0260

FAX：(07)371-3864. 371-3882.

大發工廠：高雄市大寮區大發工業區華東路46號(83162)

電話：(07)788-1179. FAX:(07)787-2303

WEB SITE: www.bothwell.com.tw
E-MAIL: sales@bothwell.com.tw
box@bothwell.com.tw

Millimeters

CAT. NO: 1603